

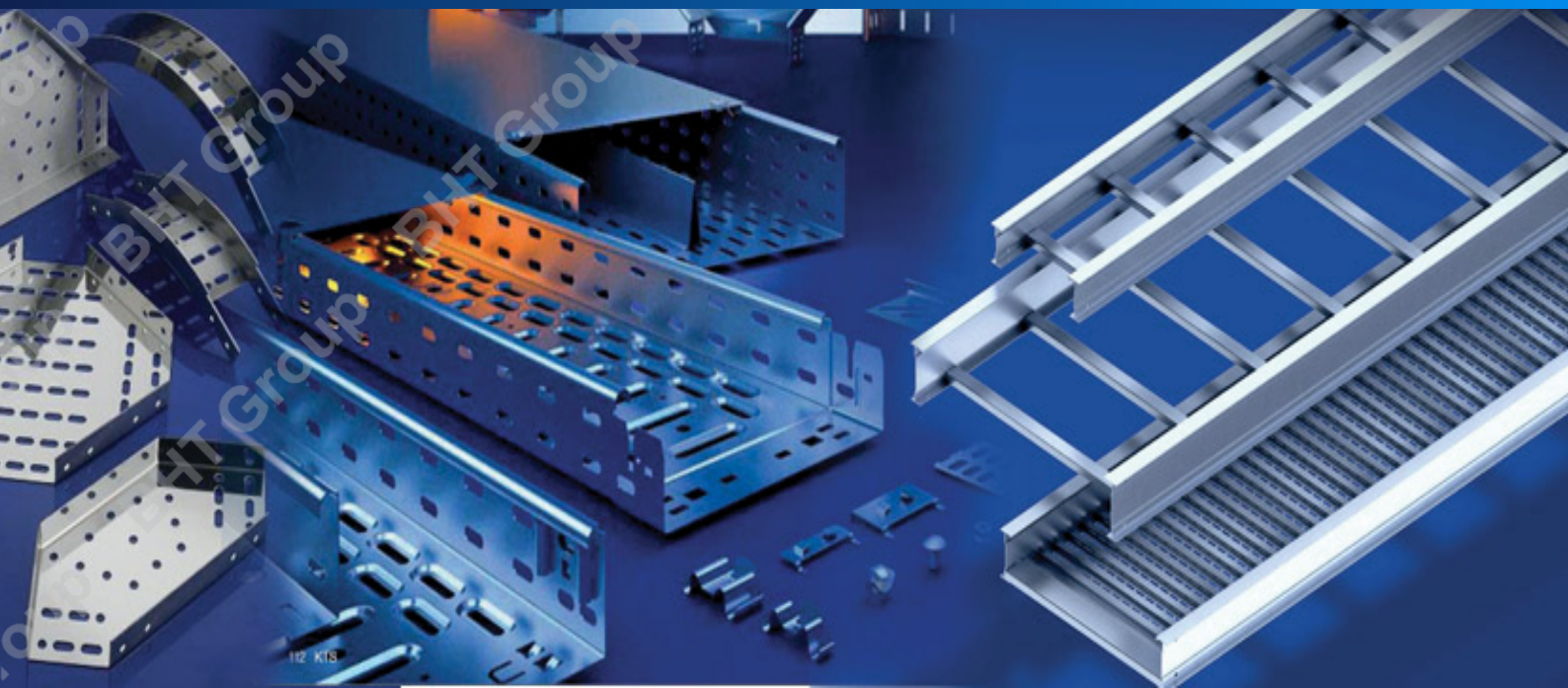

# CATALOGUE THANG MÁNG CÁP

CABLE LADDER - CABLE TRAY - CABLE TRUNKING



# VỀ CHÚNG TÔI

## About Us

Được thành lập từ năm 2004, BHT Group là nhà sản xuất hàng đầu trong lĩnh vực sản xuất thang máng cáp, luôn cam kết mang đến cho khách hàng các sản phẩm chất lượng cao và giải pháp hiệu quả.

Với sự đầu tư mạnh mẽ vào công nghệ hiện đại và quy trình sản xuất tự động hóa, BHT Group đảm bảo đáp ứng tốt các yêu cầu khắt khe về tiến độ và chất lượng trong mọi dự án.

- Chứng nhận hệ thống quản lý chất lượng ISO 9001:2015
- Chứng nhận hệ thống quản lý môi trường ISO 14001:2015
- Chứng nhận hợp chuẩn, hợp quy.

*Established in 2024, BHT Group is a leading manufacturer in the field of cable tray ladder manufacturing, always committed to providing customers with high quality products and effective solutions.*

*With strong investment in modern technology and automated production processes, BHT Group ensures to meet the strict requirements for progress and quality in every project.*

- ISO 9001:2015 Quality Management System Certification
- ISO 14001:2015 Environmental Management System Certification
- Certificate of standard and regulation conformity



### 1. CÔNG NGHỆ SẢN XUẤT & CHỨNG NHẬN PRODUCTION TECHNOLOGY & CERTIFICATION

Công nghệ sản xuất & Quy trình sản xuất thang máng cáp .....	04
<i>Production technology &amp; Cable ladder manufacturing process</i>	
Chứng nhận .....	05
<i>Certifications</i>	

### 2. THANG CÁP / CABLE LADDER

Thanh thẳng .....	06
<i>Straight ladder</i>	
Co ngang 90° / Co ngang 45° / Co chữ T .....	07
<i>Horizontal elbow 90o / Horizontal elbow 45o / Horizontal T</i>	
Co T đứng trực ngang / Co T đứng trực dọc .....	08
<i>T shaped hinge horizontal / T shaped hinge vertical</i>	
Co lên 90° / Co xuống 90° .....	09
<i>Internal riser 90° / External riser 90°</i>	
Co lên 45° / Co xuống 45° / Co chữ thập .....	10
<i>Internal riser 45° / External riser 45° / Horizontal cross</i>	
Co Z đứng / Co Z ngang phải / Co Z ngang trái .....	11
<i>Vertical Z / Right horizontal Z / Left horizontal Z</i>	
Co giảm phải / Co giảm trái / Co giảm giữa .....	12
<i>Right reducer / Left reducer / Offset reducer</i>	
Tham khảo .....	13
<i>Explore more</i>	

### 3. KHAY CÁP / CABLE TRAY

Thanh thẳng .....	14
<i>Straight ladder</i>	
Co ngang 90° / Co ngang 45° / Co chữ T .....	15
<i>Horizontal elbow 90o / Horizontal elbow 45o / Horizontal T</i>	
Co T đứng trực ngang / Co T đứng trực dọc .....	16
<i>T shaped hinge horizontal / T shaped hinge vertical</i>	
Co lên 90° / Co xuống 90° .....	17
<i>Internal riser 90o / External riser 90o</i>	
Co lên 45° / Co xuống 45° / Co chữ thập .....	18
<i>Internal riser 45o / External riser 45o / Horizontal cross</i>	
Co Z đứng / Co Z ngang phải / Co Z ngang trái .....	19
<i>Vertical Z / Right horizontal Z / Left horizontal Z</i>	
Co giảm phải / Co giảm trái / Co giảm giữa .....	20
<i>Right reducer / Left reducer / Offset reducer</i>	
Tham khảo .....	21
<i>Explore more</i>	

### 4. MÁNG CÁP / CABLE TRUNKING

Thanh thẳng .....	23
<i>Straight ladder</i>	
Co ngang 90° / Co ngang 45° / Co chữ T .....	24
<i>Horizontal elbow 90o / Horizontal elbow 45o / Horizontal T</i>	
Co T đứng trực ngang / Co T đứng trực dọc .....	25
<i>T shaped hinge horizontal / T shaped hinge vertical</i>	
Co lên 90° / Co xuống 90° .....	26
<i>Internal riser 90° / External riser 90°</i>	
Co lên 45° / Co xuống 45° / Co chữ thập .....	27
<i>Internal riser 45° / External riser 45° / Horizontal cross</i>	
Co Z đứng / Co Z ngang phải / Co Z ngang trái .....	28
<i>Vertical Z / Right horizontal Z / Left horizontal Z</i>	
Co giảm phải / Co giảm trái / Co giảm giữa .....	29
<i>Right reducer / Left reducer / Offset reducer</i>	
Phụ kiện & Tham khảo .....	30

# 1. CÔNG NGHỆ SẢN XUẤT & CHỨNG NHẬN

## Production technology & Certification

### Công nghệ sản xuất

Production technology



### Quy trình sản xuất thang máng cáp

Cable ladder manufacturing process

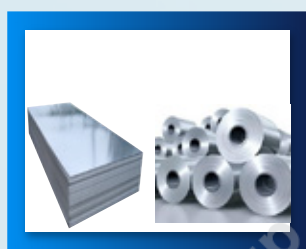

Nguyên liệu: Thép tấm, băng cuộn  
Prepare materials: Steel plate, tape rolls



Quy trình cắt, cán rail, cán rung  
Cutting process, rail rolling, vibration rolling



Quy trình đột  
Punching process



Quy trình chấn hoặc cán biên dạng  
Bending or rolling profile process



Quy trình hàn  
Welding process



Vệ sinh công nghiệp  
Industrial hygiene



Quy trình sơn tĩnh điện/ nhúng nóng  
Powder coating/hot dip process



Quy trình kiểm tra, đóng gói, xuất xưởng  
Process of checking, packing and shipping

# 1. CÔNG NGHỆ SẢN XUẤT & CHỨNG NHẬN

## Production technology & Certification



## CHỨNG NHẬN HỢP CHUẨN - HỢP QUY

Certificate of standard and regulation conformity



### HỆ THỐNG QUẢN LÝ CHẤT LƯỢNG

Quality management system

### HỆ THỐNG QUẢN LÝ MÔI TRƯỜNG

Environmental management system

## 2. THANG CẤP / Cable Ladder

### Thanh thẳng / Straight ladder

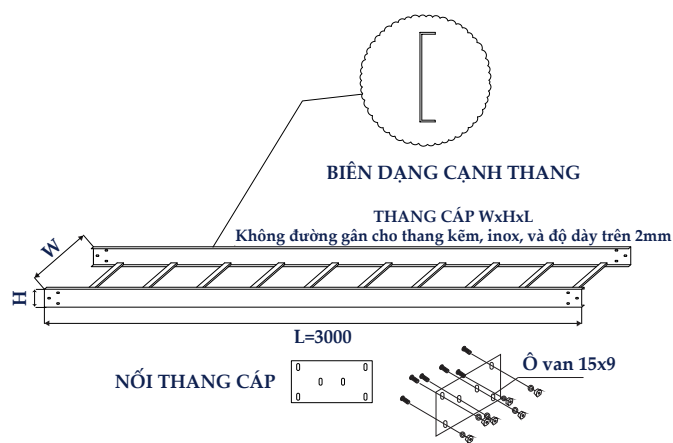
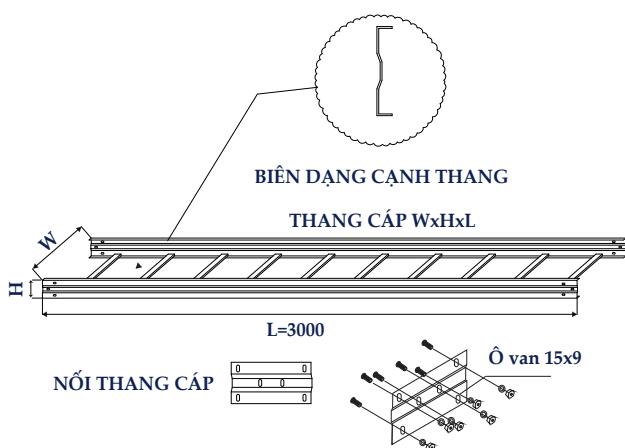

#### 1. Vật liệu / Material

- Thép tấm tráng kẽm (JIS 3302).
- Thép tấm đen (cán nóng, cán nguội).
- Thép tấm không gỉ SS304, SS316.
- Pre galvanized steel sheet (JIS 3302).
- Mild steel sheet (hot rolled, cold rolled).
- Stainless steel sheet 304,316.

#### 2. Hoàn thiện sản phẩm / Finish

- Bề mặt tự nhiên của vật liệu đối với sản phẩm tôn tráng kẽm, thép không gỉ.
- Mạ nhúng nóng.
- Sơn tĩnh điện
- Nature - protection for pre galvanized and stainless steel sheet.
- Hot dip galvanized - HDG.
- Power coated - PC

#### 3. Độ dài tiêu chuẩn / Standard length

3.0m/ thanh

3.0m/ length

#### Tên hàng Item

#### Rộng x Cao x Dày W x H x T

#### L Cable ladder, light duty

1.2 thickness  
50mm high  
75mm high  
100mm high

50 x 50 x 1.2  
75 x ( 50, 75 ) x 1.2  
100 x ( 50, 75, 100 ) x 1.2  
150 x ( 50, 75, 100 ) x 1.2  
200 x ( 50, 75, 100 ) x 1.2  
300 x ( 50, 75, 100 ) x 1.2

#### M Cable ladder, medium duty

1.5 thickness  
75mm high  
100mm high

100 x ( 75, 100 ) x 1.5  
200 x ( 75, 100 ) x 1.5  
300 x ( 75, 100 ) x 1.5  
400 x ( 75, 100 ) x 1.5  
500 x ( 75, 100 ) x 1.5  
600 x ( 75, 100 ) x 1.5  
700 x ( 75, 100 ) x 1.5  
800 x ( 75, 100 ) x 1.5

#### H Cable ladder, heavy duty

2.0 thickness  
75mm high  
100mm high  
125mm high  
150mm high

200 x ( 75, 100, 125, 150 ) x 2.0  
300 x ( 75, 100, 125, 150 ) x 2.0  
400 x ( 75, 100, 125, 150 ) x 2.0  
500 x ( 75, 100, 125, 150 ) x 2.0  
600 x ( 75, 100, 125, 150 ) x 2.0  
700 x ( 75, 100, 125, 150 ) x 2.0  
800 x ( 75, 100, 125, 150 ) x 2.0  
900 x ( 75, 100, 125, 150 ) x 2.0  
1000 x ( 75, 100, 125, 150 ) x 2.0

#### F Cable ladder, fittings

Bulong đầu dẹt cổ vuông - Mushroom head square neck bolt M8 x12  
Long dẹt - Flat washer M8  
Con tán - Hex nut M8  
Miếng nối thang cấp - Ladder connector

#### Note: Material thickness: 1, 1.2, 1.5, 2.0

Xin xác định vật liệu khi gửi yêu cầu / Please confirm material on your request

Tôn tráng kẽm  
Pre galvanized steel

Mạ nhúng nóng - HDG  
Hot dip galvanized - HDG

Sơn tĩnh điện - PC  
Power coated - PC

Thép không gỉ  
Stainless steel

## 2. THANG CẤP / Cable Ladder

### Co ngang 90° / Co ngang 45° / Co chữ T

Horizontal elbow 90° / Horizontal elbow 45° / Horizontal T

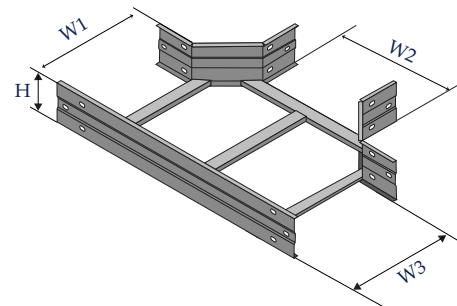
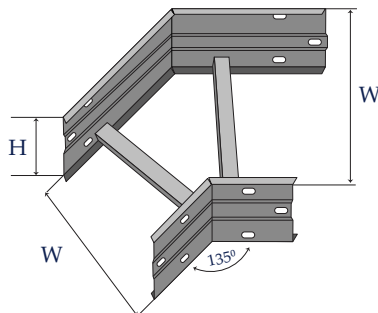
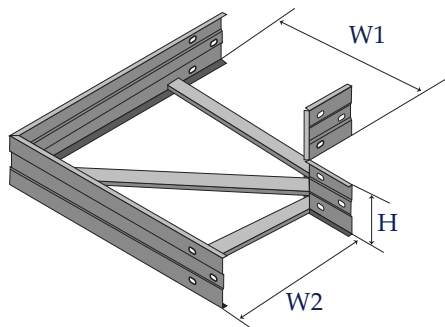

Co ngang 90° - Horizontal elbow 90°

Co ngang 45° - Horizontal elbow 45°

Co chữ T - Horizontal T

#### 1. Vật liệu / Material

- Thép tấm tráng kẽm (JIS 3302).
- Thép tấm đen (cán nóng, cán nguội).
- Thép tấm không gỉ SS304, SS316.
- Pre galvanized steel sheet (JIS 3302).
- Mild steel sheet (hot rolled, cold rolled).
- Stainless steel sheet 304,316.

#### 2. Hoàn thiện sản phẩm / Finish

- Bề mặt tự nhiên của vật liệu đối với sản phẩm tôn tráng kẽm, thép không gỉ.
- Mạ nhúng nóng.
- Sơn tĩnh điện
- Nature - protection for pre galvanized and stainless steel sheet.
- Hot dip galvanized - HDG.
- Power coated - PC

#### 3. Độ dài tiêu chuẩn / Standard length

3.0m/ thanh

3.0m/ length

#### Tên hàng Item

#### Rộng x Cao x Dày W x H x T

#### L Cable ladder, light duty

1.2 thickness  
50mm high  
75mm high  
100mm high

50 x 50 x 1.2  
75 x ( 50, 75 ) x 1.2  
100 x ( 50, 75, 100 ) x 1.2  
150 x ( 50, 75, 100 ) x 1.2  
200 x ( 50, 75, 100 ) x 1.2  
300 x ( 50, 75, 100 ) x 1.2

#### M Cable ladder, medium duty

1.5 thickness  
75mm high  
100mm high

100 x ( 75, 100 ) x 1.5  
200 x ( 75, 100 ) x 1.5  
300 x ( 75, 100 ) x 1.5  
400 x ( 75, 100 ) x 1.5  
500 x ( 75, 100 ) x 1.5  
600 x ( 75, 100 ) x 1.5  
700 x ( 75, 100 ) x 1.5  
800 x ( 75, 100 ) x 1.5

#### H Cable ladder, heavy duty

2.0 thickness  
75mm high  
100mm high  
125mm high  
150mm high

200 x ( 75, 100, 125, 150 ) x 2.0  
300 x ( 75, 100, 125, 150 ) x 2.0  
400 x ( 75, 100, 125, 150 ) x 2.0  
500 x ( 75, 100, 125, 150 ) x 2.0  
600 x ( 75, 100, 125, 150 ) x 2.0  
700 x ( 75, 100, 125, 150 ) x 2.0  
800 x ( 75, 100, 125, 150 ) x 2.0  
900 x ( 75, 100, 125, 150 ) x 2.0  
1000 x ( 75, 100, 125, 150 ) x 2.0

#### F Cable ladder, fittings

Bulong đầu dẹt cổ vuông - Mushroom head square neck bolt M8 x12  
Long dẹt - Flat washer M8  
Con tán - Hex nut M8  
Miếng nối thang cáp - Ladder connector

#### • Note: Material thickness: 1, 1.2, 1.5, 2.0

Xin xác định vật liệu khi gửi yêu cầu / Please confirm material on your request

Tôn tráng kẽm  
Pre galvanized steel

Mạ nhúng nóng - HDG  
Hot dip galvanized - HDG

Sơn tĩnh điện - PC  
Power coated - PC

Thép không gỉ  
Stainless steel

## 2. THANG CẤP / Cable Ladder

### Co T đứng trực ngang / Co T đứng trực dọc

*T shaped hinge horizontal / T shaped hinge vertical*

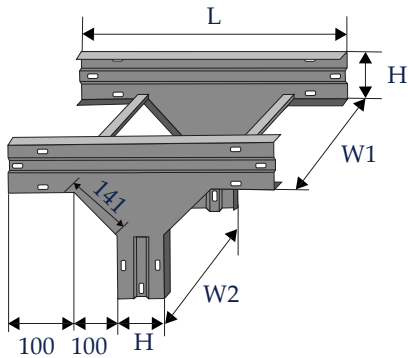

Co T đứng trực ngang - *T shaped hinge horizontal*

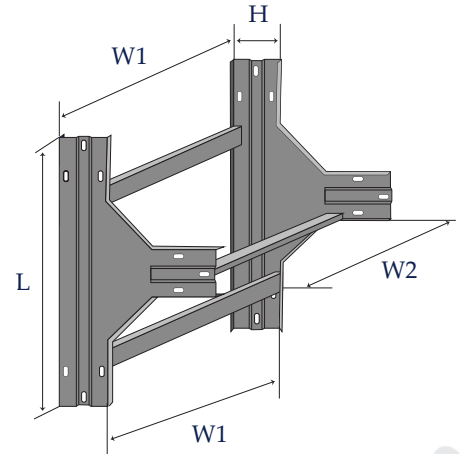

Co T đứng trực dọc - *T shaped hinge vertical*

#### 1. Vật liệu / Material

- Thép tấm tráng kẽm (JIS 3302).
- Thép tấm đen (cán nóng, cán nguội).
- Thép tấm không gỉ SS304, SS316.
- *Pre galvanized steel sheet (JIS 3302).*
- *Mild steel sheet (hot rolled, cold rolled).*
- *Stainless steel sheet 304,316.*

#### 2. Hoàn thiện sản phẩm / Finish

- Bề mặt tự nhiên của vật liệu đối với sản phẩm tôn tráng kẽm, thép không gỉ.
- Mạ nhúng nóng.
- Sơn tĩnh điện
- *Nature - protection for pre galvanized and stainless steel sheet.*
- *Hot dip galvanized - HDG.*
- *Power coated - PC*

#### 3. Độ dài tiêu chuẩn / Standard length

3.0m/ thanh

3.0m/ length

#### Tên hàng Item

#### Rộng x Cao x Dày W x H x T

#### L Cable ladder, light duty

1.2 thickness  
50mm high  
75mm high  
100mm high

50 x 50 x 1.2  
75 x ( 50, 75) x 1.2  
100 x ( 50, 75, 100) x 1.2  
150 x ( 50, 75, 100) x 1.2  
200 x ( 50, 75, 100) x 1.2  
300 x ( 50, 75, 100) x 1.2

#### M Cable ladder, medium duty

1.5 thickness  
75mm high  
100mm high

100 x ( 75, 100) x 1.5  
200 x ( 75, 100) x 1.5  
300 x ( 75, 100) x 1.5  
400 x ( 75, 100) x 1.5  
500 x ( 75, 100) x 1.5  
600 x ( 75, 100) x 1.5  
700 x ( 75, 100) x 1.5  
800 x ( 75, 100) x 1.5

#### H Cable ladder, heavy duty

2.0 thickness  
75mm high  
100mm high  
125mm high  
150mm high

200 x ( 75, 100, 125, 150) x 2.0  
300 x ( 75, 100, 125, 150) x 2.0  
400 x ( 75, 100, 125, 150) x 2.0  
500 x ( 75, 100, 125, 150) x 2.0  
600 x ( 75, 100, 125, 150) x 2.0  
700 x ( 75, 100, 125, 150) x 2.0  
800 x ( 75, 100, 125, 150) x 2.0  
900 x ( 75, 100, 125, 150) x 2.0  
1000 x ( 75, 100, 125, 150) x 2.0

#### F Cable ladder, fittings

- Bulong đầu dẹt cổ vuông - *Mushroom head square neck bolt M8 x12*
- Long dẹt - *Flat washer M8*
- Con tán - *Hex nut M8*
- Miếng nối thang cáp - *Ladder connector*

#### • Note: Material thickness: 1, 1.2, 1.5, 2.0

Xin xác định vật liệu khi gửi yêu cầu / *Please confirm material on your request*

Tôn tráng kẽm  
*Pre galvanized steel*

Mạ nhúng nóng - HDG  
*Hot dip galvanized - HDG*

Sơn tĩnh điện - PC  
*Power coated - PC*

Thép không gỉ  
*Stainless steel*

## 2. THANG CẤP / Cable Ladder

### Co lên 90° / Co xuống 90°

Internal riser 90° / External riser 90°

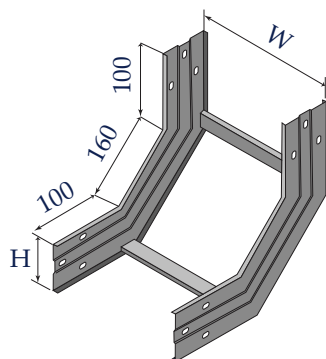

Co lên 90° - Internal riser 90°

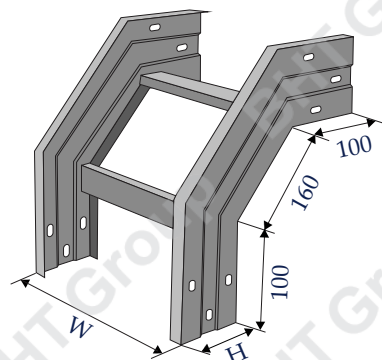

Co xuống 90° - External riser 90°

### 1. Vật liệu / Material

- Thép tấm tráng kẽm (JIS 3302).
- Thép tấm đen (cán nóng, cán nguội).
- Thép tấm không gỉ SS304, SS316.
- Pre galvanized steel sheet (JIS 3302).
- Mild steel sheet (hot rolled, cold rolled).
- Stainless steel sheet 304,316.

### 2. Hoàn thiện sản phẩm / Finish

- Bề mặt tự nhiên của vật liệu đối với sản phẩm tôn tráng kẽm, thép không gỉ.
- Mạ nhúng nóng.
- Sơn tĩnh điện
- Nature - protection for pre galvanized and stainless steel sheet.
- Hot dip galvanized - HDG.
- Power coated - PC

### 3. Độ dài tiêu chuẩn / Standard length

3.0m/ thanh

3.0m/ length

### Tên hàng Item

### Rộng x Cao x Dày W x H x T

#### L Cable ladder, light duty

1.2 thickness  
50mm high  
75mm high  
100mm high

50 x 50 x 1.2  
75 x ( 50, 75 ) x 1.2  
100 x ( 50, 75, 100 ) x 1.2  
150 x ( 50, 75, 100 ) x 1.2  
200 x ( 50, 75, 100 ) x 1.2  
300 x ( 50, 75, 100 ) x 1.2

#### M Cable ladder, medium duty

1.5 thickness  
75mm high  
100mm high

100 x ( 75, 100 ) x 1.5  
200 x ( 75, 100 ) x 1.5  
300 x ( 75, 100 ) x 1.5  
400 x ( 75, 100 ) x 1.5  
500 x ( 75, 100 ) x 1.5  
600 x ( 75, 100 ) x 1.5  
700 x ( 75, 100 ) x 1.5  
800 x ( 75, 100 ) x 1.5

#### H Cable ladder, heavy duty

2.0 thickness  
75mm high  
100mm high  
125mm high  
150mm high

200 x ( 75, 100, 125, 150 ) x 2.0  
300 x ( 75, 100, 125, 150 ) x 2.0  
400 x ( 75, 100, 125, 150 ) x 2.0  
500 x ( 75, 100, 125, 150 ) x 2.0  
600 x ( 75, 100, 125, 150 ) x 2.0  
700 x ( 75, 100, 125, 150 ) x 2.0  
800 x ( 75, 100, 125, 150 ) x 2.0  
900 x ( 75, 100, 125, 150 ) x 2.0  
1000 x ( 75, 100, 125, 150 ) x 2.0

#### F Cable ladder, fittings

Bulong đầu dẹt cổ vuông - Mushroom head square neck bolt M8 x12  
Long dẹt - Flat washer M8  
Con tán - Hex nut M8  
Miếng nối thang cáp - Ladder connector

### • Note: Material thickness: 1, 1.2, 1.5, 2.0

Xin xác định vật liệu khi gửi yêu cầu / Please confirm material on your request

Tôn tráng kẽm  
Pre galvanized steel

Mạ nhúng nóng - HDG  
Hot dip galvanized - HDG

Sơn tĩnh điện - PC  
Power coated - PC

Thép không gỉ  
Stainless steel

## 2. THANG CẤP / Cable Ladder

### Co lên 45° / Co xuống 45° / Co chữ thập

Internal riser 45° / External riser 45° / Horizontal cross

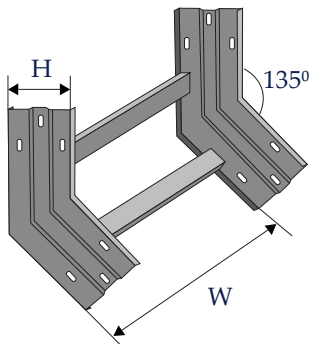

Co lên 45° - Internal riser 45°

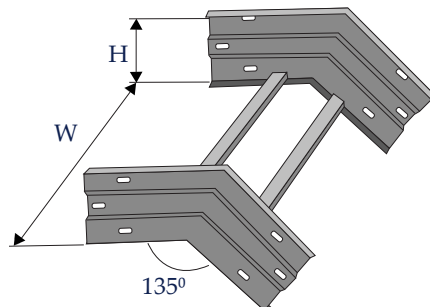

Co xuống 45° - External riser 45°

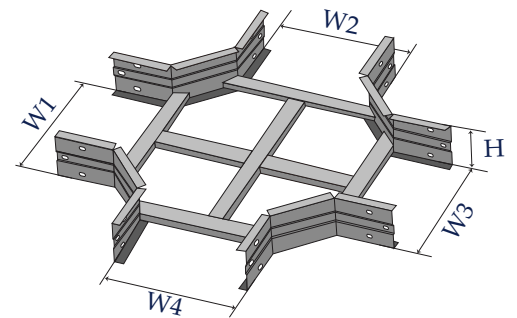

Co chữ thập - Horizontal cross

#### 1. Vật liệu / Material

- Sắt tấm tráng kẽm (JIS 3302).
- Sắt tấm đen (cán nóng, cán nguội).
- Thép tấm không gỉ SS304, SS316.
- Pre galvanized steel sheet (JIS 3302).
- Mild steel sheet (hot rolled, cold rolled).
- Stainless steel sheet 304,316.

#### 2. Hoàn thiện sản phẩm / Finish

- Bề mặt tự nhiên của vật liệu đối với sản phẩm tôn tráng kẽm, thép không gỉ.
- Mạ nhúng nóng.
- Sơn tĩnh điện
- Nature - protection for pre galvanized and stainless steel sheet.
- Hot dip galvanized - HDG.
- Power coated - PC

#### 3. Độ dài tiêu chuẩn / Standard length

3.0m/ thanh

3.0m/ length

#### Tên hàng Item

#### Rộng x Cao x Dày W x H x T

#### L Cable ladder, light duty

1.2 thickness  
50mm high  
75mm high  
100mm high

50 x 50 x 1.2  
75 x ( 50, 75 ) x 1.2  
100 x ( 50, 75, 100 ) x 1.2  
150 x ( 50, 75, 100 ) x 1.2  
200 x ( 50, 75, 100 ) x 1.2  
300 x ( 50, 75, 100 ) x 1.2

#### M Cable ladder, medium duty

1.5 thickness  
75mm high  
100mm high

100 x ( 75, 100 ) x 1.5  
200 x ( 75, 100 ) x 1.5  
300 x ( 75, 100 ) x 1.5  
400 x ( 75, 100 ) x 1.5  
500 x ( 75, 100 ) x 1.5  
600 x ( 75, 100 ) x 1.5  
700 x ( 75, 100 ) x 1.5  
800 x ( 75, 100 ) x 1.5

#### H Cable ladder, heavy duty

2.0 thickness  
75mm high  
100mm high  
125mm high  
150mm high

200 x 75 x ( 100, 125, 150 ) x 2.0  
300 x 75 x ( 100, 125, 150 ) x 2.0  
400 x 75 x ( 100, 125, 150 ) x 2.0  
500 x 75 x ( 100, 125, 150 ) x 2.0  
600 x 75 x ( 100, 125, 150 ) x 2.0  
700 x 75 x ( 100, 125, 150 ) x 2.0  
800 x 75 x ( 100, 125, 150 ) x 2.0  
900 x 75 x ( 100, 125, 150 ) x 2.0  
1000 x 75 x ( 100, 125, 150 ) x 2.0

#### F Cable ladder, fittings

Bulong đầu dùi cổ vuông - Mushroom head square neck bolt M8 x12  
Long dẹt - Flat washer M8  
Con tán - Hex nut M8  
Miếng nối thang cấp - Ladder connector

#### Note: Material thickness: 1, 1.2, 1.5, 2.0

Xin xác định vật liệu khi gửi yêu cầu / Please confirm material on your request

Tôn tráng kẽm  
Pre galvanized steel

Mạ nhúng nóng - HDG  
Hot dip galvanized - HDG

Sơn tĩnh điện - PC  
Power coated - PC

Thép không gỉ  
Stainless steel

## 2. THANG CẤP / Cable Ladder

### Co Z đứng / Co Z ngang phải/ Co Z ngang trái

Vertical Z / Right horizontal Z / Left horizontal Z

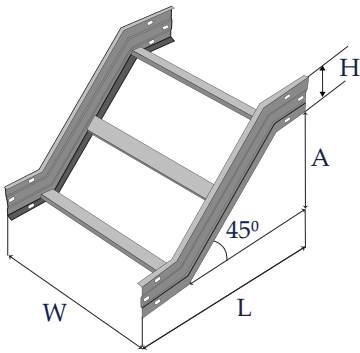

Co Z đứng - Internal riser 45°

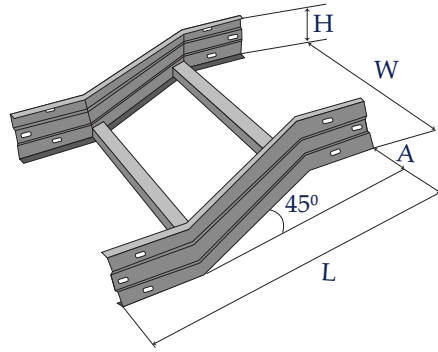

Co Z ngang phải - Right horizontal Z

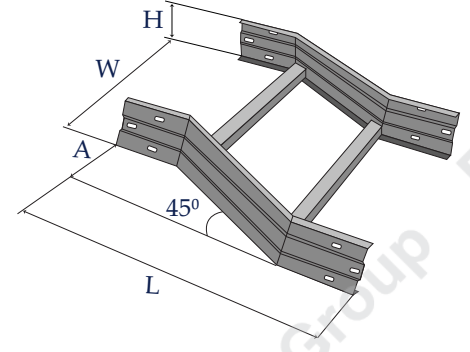

Co Z ngang trái - Left horizontal Z

#### 1. Vật liệu / Material

- Thép tấm tráng kẽm (JIS 3302).
- Thép tấm đen (cán nóng, cán nguội).
- Thép tấm không gỉ SS304, SS316.
- Pre galvanized steel sheet (JIS 3302).
- Mild steel sheet (hot rolled, cold rolled).
- Stainless steel sheet 304,316.

#### 2. Hoàn thiện sản phẩm / Finish

- Bề mặt tự nhiên của vật liệu đối với sản phẩm tôn tráng kẽm, thép không gỉ.
- Mạ nhúng nóng.
- Sơn tĩnh điện
- Nature - protection for pre galvanized and stainless steel sheet.
- Hot dip galvanized - HDG.
- Power coated - PC

#### 3. Độ dài tiêu chuẩn / Standard length

3.0m/ thanh

3.0m/ length

#### Tên hàng Item

#### Rộng x Cao x Dày W x H x T

#### L Cable ladder, light duty

1.2 thickness  
50mm high  
75mm high  
100mm high

50 x 50 x 1.2  
75 x ( 50, 75) x 1.2  
100 x ( 50, 75, 100) x 1.2  
150 x ( 50, 75, 100) x 1.2  
200 x ( 50, 75, 100) x 1.2  
300 x ( 50, 75, 100) x 1.2

#### M Cable ladder, medium duty

1.5 thickness  
75mm high  
100mm high

100 x ( 75, 100) x 1.5  
200 x ( 75, 100) x 1.5  
300 x ( 75, 100) x 1.5  
400 x ( 75, 100) x 1.5  
500 x ( 75, 100) x 1.5  
600 x ( 75, 100) x 1.5  
700 x ( 75, 100) x 1.5  
800 x ( 75, 100) x 1.5

#### H Cable ladder, heavy duty

2.0 thickness  
75mm high  
100mm high  
125mm high  
150mm high

200 x ( 75, 100, 125, 150) x 2.0  
300 x ( 75, 100, 125, 150) x 2.0  
400 x ( 75, 100, 125, 150) x 2.0  
500 x ( 75, 100, 125, 150) x 2.0  
600 x ( 75, 100, 125, 150) x 2.0  
700 x ( 75, 100, 125, 150) x 2.0  
800 x ( 75, 100, 125, 150) x 2.0  
900 x ( 75, 100, 125, 150) x 2.0  
1000 x ( 75, 100, 125, 150) x 2.0

#### F Cable ladder, fittings

Bulong đầu dẹt cổ vuông - Mushroom head square neck bolt M8 x12  
Long dẹt - Flat washer M8  
Con tán - Hex nut M8  
Miếng nối thang cáp - Ladder connector

#### • Note: Material thickness: 1, 1.2, 1.5, 2.0

Xin xác định vật liệu khi gửi yêu cầu / Please confirm material on your request

Tôn tráng kẽm  
Pre galvanized steel

Mạ nhúng nóng - HDG  
Hot dip galvanized - HDG

Sơn tĩnh điện - PC  
Power coated - PC

Thép không gỉ  
Stainless steel

## 2. THANG CẤP / Cable Ladder

### Co giảm phải / Co giảm trái / Co giảm giữa

Right reducer / Left reducer / Offset reducer

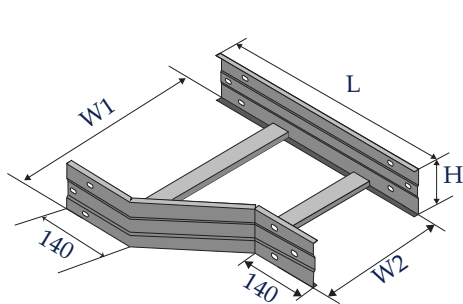

Co giảm phải - Right reducer

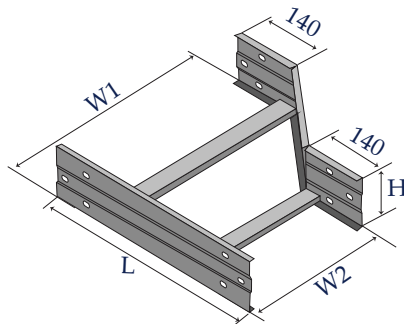

Co giảm trái - Left reducer

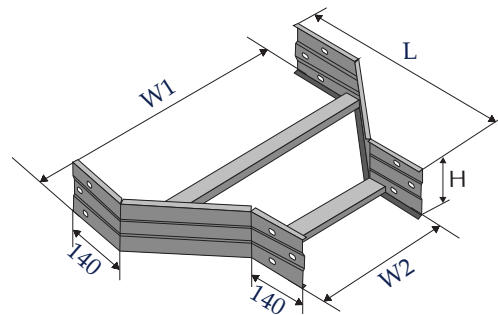

Co giảm giữa - Offset reducer

#### 1. Vật liệu / Material

- Thép tấm tráng kẽm (JIS 3302).
- Thép tấm đen (cán nóng, cán nguội).
- Thép tấm không gỉ SS304, SS316.
- Pre galvanized steel sheet (JIS 3302).
- Mild steel sheet (hot rolled, cold rolled).
- Stainless steel sheet 304,316.

#### 2. Hoàn thiện sản phẩm / Finish

- Bề mặt tự nhiên của vật liệu đối với sản phẩm tôn tráng kẽm, thép không gỉ.
- Mạ nhúng nóng.
- Sơn tĩnh điện
- Nature - protection for pre galvanized and stainless steel sheet.
- Hot dip galvanized - HDG.
- Power coated - PC

#### 3. Độ dài tiêu chuẩn / Standard length

3.0m/ thanh

3.0m/ length

#### Tên hàng Item

#### Rộng x Cao x Dày W x H x T

#### L Cable ladder, light duty

1.2 thickness  
50mm high  
75mm high  
100mm high

50 x 50 x 1.2  
75 x ( 50, 75 ) x 1.2  
100 x ( 50, 75, 100 ) x 1.2  
150 x ( 50, 75, 100 ) x 1.2  
200 x ( 50, 75, 100 ) x 1.2  
300 x ( 50, 75, 100 ) x 1.2

#### M Cable ladder, medium duty

1.5 thickness  
75mm high  
100mm high

100 x ( 75, 100 ) x 1.5  
200 x ( 75, 100 ) x 1.5  
300 x ( 75, 100 ) x 1.5  
400 x ( 75, 100 ) x 1.5  
500 x ( 75, 100 ) x 1.5  
600 x ( 75, 100 ) x 1.5  
700 x ( 75, 100 ) x 1.5  
800 x ( 75, 100 ) x 1.5

#### H Cable ladder, heavy duty

2.0 thickness  
75mm high  
100mm high  
125mm high  
150mm high

200 x ( 75, 100, 125, 150 ) x 2.0  
300 x ( 75, 100, 125, 150 ) x 2.0  
400 x ( 75, 100, 125, 150 ) x 2.0  
500 x ( 75, 100, 125, 150 ) x 2.0  
600 x ( 75, 100, 125, 150 ) x 2.0  
700 x ( 75, 100, 125, 150 ) x 2.0  
800 x ( 75, 100, 125, 150 ) x 2.0  
900 x ( 75, 100, 125, 150 ) x 2.0  
1000 x ( 75, 100, 125, 150 ) x 2.0

#### F Cable ladder, fittings

Bulong đầu dẹt cổ vuông - Mushroom head square neck bolt M8 x12  
Long dẹt - Flat washer M8  
Con tán - Hex nut M8  
Miếng nối thang cấp - Ladder connector

#### Note: Material thickness: 1, 1.2, 1.5, 2.0

Xin xác định vật liệu khi gửi yêu cầu / Please confirm material on your request

Tôn tráng kẽm  
Pre galvanized steel

Mạ nhúng nóng - HDG  
Hot dip galvanized - HDG

Sơn tĩnh điện - PC  
Power coated - PC

Thép không gỉ  
Stainless steel

Tiêu chuẩn: H100 có gân cạnh

Loại đặc biệt: + H50, H75, H>100 Không có gân

+ Vật liệu: tôn kẽm, inox, độ dày > 2mm

+ Thanh rung có đục lỗ

Standard: H100 has ribbed edges

Special types: + H50, H75, H>100 No ribs

+ Materials: zinc plate, stainless steel, thickness > 2mm

+ Perforated vibration bar

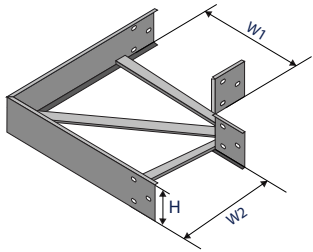

**Co ngang 90°**  
*Horizontal elbow 90°*

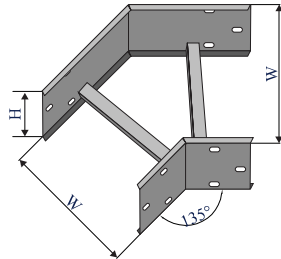

**Co ngang 45°**  
*Horizontal elbow 45°*

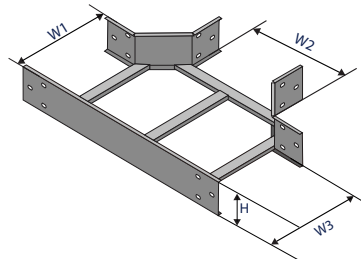

**Co chữ T**  
*Horizontal T*

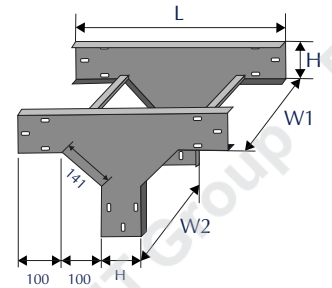

**Co T đứng trực ngang**  
*T shaped hinge horizontal*

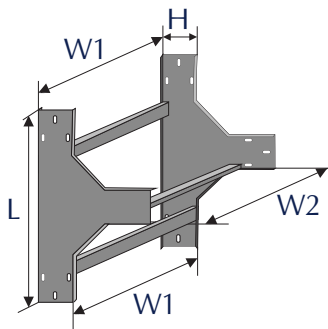

**Co T đứng trực dọc**  
*T shaped hinge vertical*

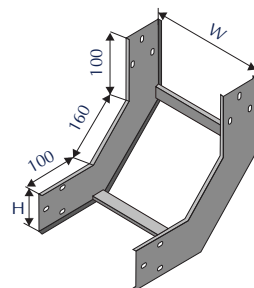

**Co lên 90°**  
*Internal riser 90°*

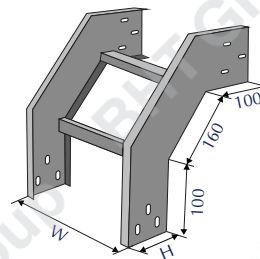

**Co xuống 90°**  
*External riser 90°*

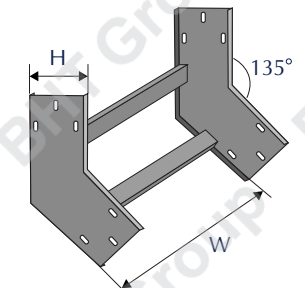

**Co lên 45°**  
*Internal riser 45°*

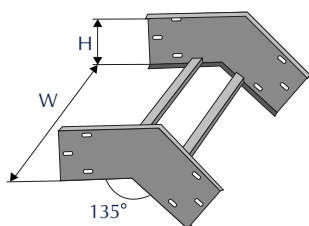

**Co xuống 45°**  
*External riser 45°*

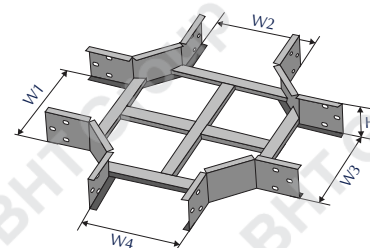

**Co ngã tư**  
*Horizontal cross*

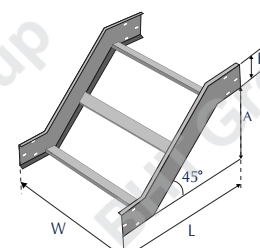

**Co đứng Z**  
*Vertical Z*

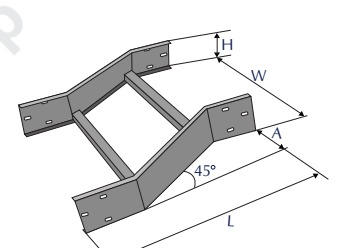

**Co Z ngang phải**  
*Right horizontal Z*

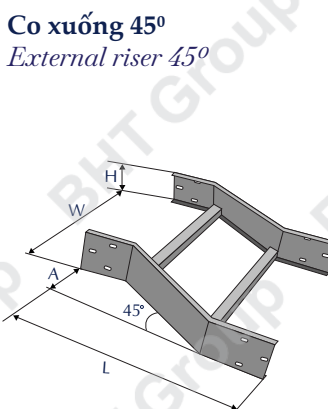

**Co Z ngang trái**  
*Left horizontal Z*

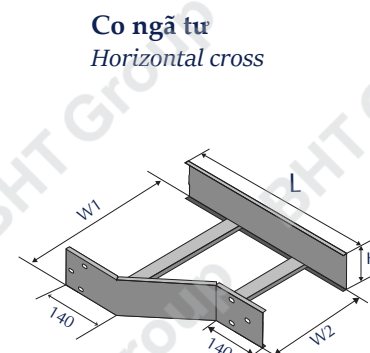

**Co giảm phải**  
*Right reducer*

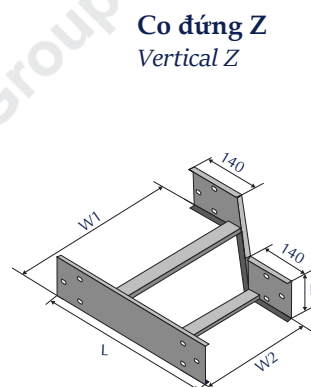

**Co giảm trái**  
*Left reducer*

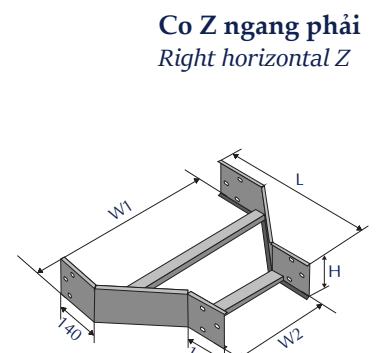

**Co giảm giữa**  
*Offset reducer*

### 3. KHAY CÁP / Cable Tray

#### Thanh thẳng / Straight ladder

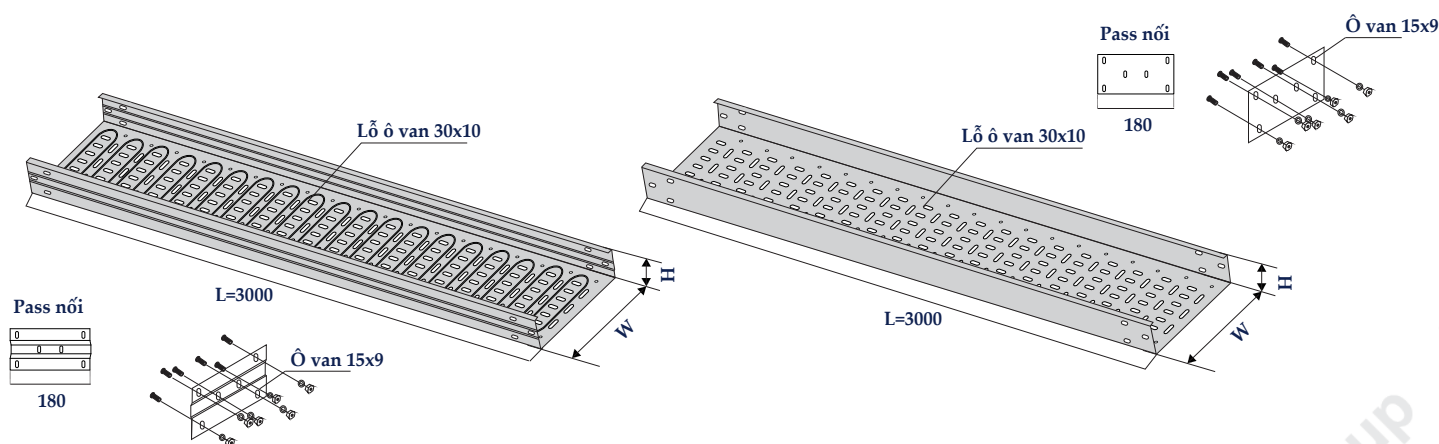

#### 1. Vật liệu / Material

- Thép tấm tráng kẽm (JIS 3302).
- Thép tấm đen (cán nóng, cán nguội).
- Thép tấm không gỉ SS304, SS316.
- Pre galvanized steel sheet (JIS 3302).
- Mild steel sheet (hot rolled, cold rolled).
- Stainless steel sheet 304,316.

#### 2. Hoàn thiện sản phẩm / Finish

- Bề mặt tự nhiên của vật liệu đối với sản phẩm tôn tráng kẽm, thép không gỉ.
- Mạ nhúng nóng.
- Sơn tĩnh điện
- Nature - protection for pre galvanized and stainless steel sheet.
- Hot dip galvanized - HDG.
- Power coated - PC

#### 3. Độ dài tiêu chuẩn / Standard length

3.0m/ thanh

3.0m/ length

#### Tên hàng / Item

#### Rộng x Cao x Dày / W x H x T

#### L Cable ladder, light duty

1.0 thickness	50 x 50 x 1.0 75 x (50,75) x 1.0	100 x (50,75,100) x 1.2
1.2 thickness		150 x (50,75,100) x 1.2
50mm high		200 x (50,75,100) x 1.2
75mm high		300 x (50,75,100) x 1.2
100mm high		400 x (50,75,100) x 1.2

#### M Cable ladder, medium duty

1.5 thickness	100 x (50, 75, 100) x 1.5
50mm high	200 x (50, 75, 100) x 1.5
75mm high	300 x (50, 75, 100) x 1.5
100mm high	400 x (50, 75, 100) x 1.5
	500 x (50, 75, 100) x 1.5
	600 x (50, 75, 100) x 1.5
	700 x (50, 75, 100) x 1.5
	800 x (50, 75, 100) x 1.5

#### H Cable ladder, heavy duty

2.0 thickness	200 x (75, 100, 125, 150) x 2.0
75mm high	300 x (75, 100, 125, 150) x 2.0
100mm high	400 x (75, 100, 125, 150) x 2.0
125mm high	500 x (75, 100, 125, 150) x 2.0
150mm high	600 x (75, 100, 125, 150) x 2.0
	700 x (75, 100, 125, 150) x 2.0
	800 x (75, 100, 125, 150) x 2.0
	900 x (75, 100, 125, 150) x 2.0
	1000 x (75, 100, 125, 150) x 2.0

#### F Cable ladder, fittings

- Bulong đầu dẹt cổ vuông - Mushroom head square neck bolt M8 x12
- Long dẹt - Flat washer M8
- Con tán - Hex nut M8
- Miếng nối thang cáp - Ladder connector

#### Note: Material thickness: 1, 1.2, 1.5, 2.0

Xin xác định vật liệu khi gửi yêu cầu / Please confirm material on your request

Tôn tráng kẽm  
Pre galvanized steel

Mạ nhúng nóng - HDG  
Hot dip galvanized - HDG

Sơn tĩnh điện - PC  
Power coated - PC

Thép không gỉ  
Stainless steel

### 3. KHAY CÁP / Cable Tray

#### Co ngang 90° / Co ngang 45° / Co chữ T

Horizontal elbow 90° / Horizontal elbow 45° / Horizontal T

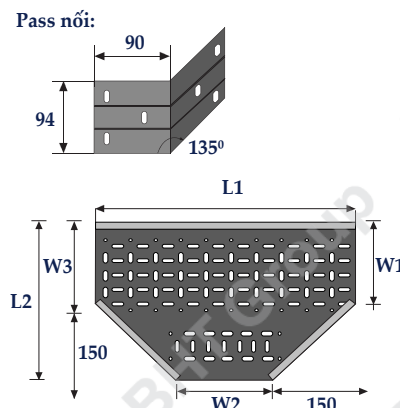
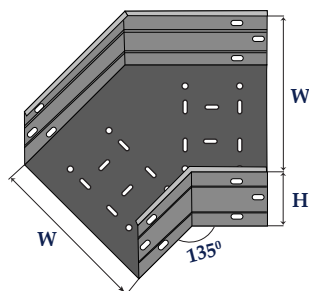
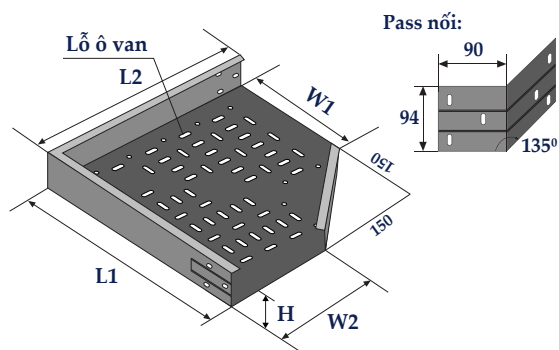

Co ngang 90° - Horizontal elbow 90°

Co ngang 45° - Horizontal elbow 45°

Co chữ T - Horizontal T

#### 1. Vật liệu / Material

- Thép tấm tráng kẽm (JIS 3302).
- Thép tấm đen (cán nóng, cán nguội).
- Thép tấm không gỉ SS304, SS316.
- Pre galvanized steel sheet (JIS 3302).
- Mild steel sheet (hot rolled, cold rolled).
- Stainless steel sheet 304,316.

#### 2. Hoàn thiện sản phẩm / Finish

- Bề mặt tự nhiên của vật liệu đối với sản phẩm tôn tráng kẽm, thép không gỉ.
- Mạ nhúng nóng.
- Sơn tĩnh điện
- Nature - protection for pre galvanized and stainless steel sheet.
- Hot dip galvanized - HDG.
- Power coated - PC

#### 3. Độ dài tiêu chuẩn / Standard length

3.0m/ thanh

3.0m/ length

#### Tên hàng Item

#### Rộng x Cao x Dày W x H x T

#### L Cable ladder, light duty

1.0 thickness	50 x 50 x 1.0 75 x (50,75) x 1.0	100 x (50,75,100) x 1.2
1.2 thickness		150 x (50,75,100) x 1.2
50mm high		200 x (50,75,100) x 1.2
75mm high		300 x (50,75,100) x 1.2
100mm high		400 x (50,75,100) x 1.2

#### M Cable ladder, medium duty

1.5 thickness	100 x (50, 75, 100) x 1.5
50mm high	200 x (50, 75, 100) x 1.5
75mm high	300 x (50, 75, 100) x 1.5
100mm high	400 x (50, 75, 100) x 1.5
	500 x (50, 75, 100) x 1.5
	600 x (50, 75, 100) x 1.5
	700 x (50, 75, 100) x 1.5
	800 x (50, 75, 100) x 1.5

#### H Cable ladder, heavy duty

2.0 thickness	200 x (75, 100, 125, 150) x 2.0
75mm high	300 x (75, 100, 125, 150) x 2.0
100mm high	400 x (75, 100, 125, 150) x 2.0
125mm high	500 x (75, 100, 125, 150) x 2.0
150mm high	600 x (75, 100, 125, 150) x 2.0
	700 x (75, 100, 125, 150) x 2.0
	800 x (75, 100, 125, 150) x 2.0
	900 x (75, 100, 125, 150) x 2.0
	1000 x (75, 100, 125, 150) x 2.0

#### F Cable ladder, fittings

- Bulong đầu dẹt cổ vuông - Mushroom head square neck bolt M8 x12
- Long dẹt - Flat washer M8
- Con tán - Hex nut M8
- Miếng nối thang cáp - Ladder connector

#### Note: Material thickness: 1, 1.2, 1.5, 2.0

Xin xác định vật liệu khi gửi yêu cầu / Please confirm material on your request

Tôn tráng kẽm  
Pre galvanized steel

Mạ nhúng nóng - HDG  
Hot dip galvanized - HDG

Sơn tĩnh điện - PC  
Power coated - PC

Thép không gỉ  
Stainless steel

### 3. KHAY CÁP / Cable Tray

#### Co T đứng trục ngang / Co T đứng trục dọc

T shaped hinge horizontal / T shaped hinge vertical

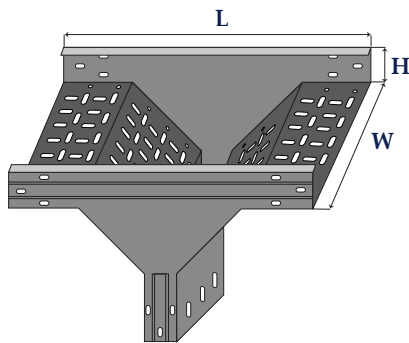

Co T đứng trục ngang - T shaped hinge horizontal

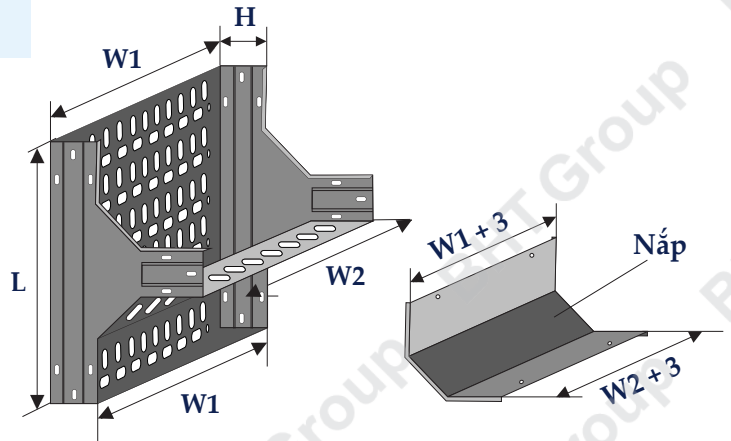

Co T đứng trục dọc - T shaped hinge vertical

#### 1. Vật liệu / Material

- Thép tấm tráng kẽm (JIS 3302).
- Thép tấm đen (cán nóng, cán nguội).
- Thép tấm không gỉ SS304, SS316.
- Pre galvanized steel sheet (JIS 3302).
- Mild steel sheet (hot rolled, cold rolled).
- Stainless steel sheet 304,316.

#### 2. Hoàn thiện sản phẩm / Finish

- Bề mặt tự nhiên của vật liệu đối với sản phẩm tôn tráng kẽm, thép không gỉ.
- Mạ nhúng nóng.
- Sơn tĩnh điện
- Nature - protection for pre galvanized and stainless steel sheet.
- Hot dip galvanized - HDG.
- Power coated - PC

#### 3. Độ dài tiêu chuẩn / Standard length

3.0m/ thanh

3.0m/ length

Tên hàng  
Item

Rộng x Cao x Dày  
W x H x T

#### L Cable ladder, light duty

1.0 thickness	50 x 50 x 1.0 75 x (50,75) x 1.0	100 x (50,75,100) x 1.2
1.2 thickness		150 x (50,75,100) x 1.2
50mm high		200 x (50,75,100) x 1.2
75mm high		300 x (50,75,100) x 1.2
100mm high		400 x (50,75,100) x 1.2

#### M Cable ladder, medium duty

1.5 thickness 50mm high 75mm high 100mm high	100 x (50, 75, 100) x 1.5
	200 x (50, 75, 100) x 1.5
	300 x (50, 75, 100) x 1.5
	400 x (50, 75, 100) x 1.5
	500 x (50, 75, 100) x 1.5
	600 x (50, 75, 100) x 1.5
700 x (50, 75, 100) x 1.5	
800 x (50, 75, 100) x 1.5	

#### H Cable ladder, heavy duty

2.0 thickness 75mm high 100mm high 125mm high 150mm high	200 x (75, 100, 125, 150) x 2.0
	300 x (75, 100, 125, 150) x 2.0
	400 x (75, 100, 125, 150) x 2.0
	500 x (75, 100, 125, 150) x 2.0
	600 x (75, 100, 125, 150) x 2.0
	700 x (75, 100, 125, 150) x 2.0
	800 x (75, 100, 125, 150) x 2.0
	900 x (75, 100, 125, 150) x 2.0
1000 x (75, 100, 125, 150) x 2.0	

#### F Cable ladder, fittings

- Bulong đầu dẹt cổ vuông - Mushroom head square neck bolt M8 x12
- Long dẹt - Flat washer M8
- Con tán - Hex nut M8
- Miếng nối thang cáp - Ladder connector

#### Note: Material thickness: 1, 1.2, 1.5, 2.0

Xin xác định vật liệu khi gửi yêu cầu / Please confirm material on your request

Tôn tráng kẽm  
Pre galvanized steel

Mạ nhúng nóng - HDG  
Hot dip galvanized - HDG

Sơn tĩnh điện - PC  
Power coated - PC

Thép không gỉ  
Stainless steel

### 3. KHAY CÁP / Cable Tray

#### Co lên 90° / Co xuống 90°

Internal riser 90° / External riser 90°

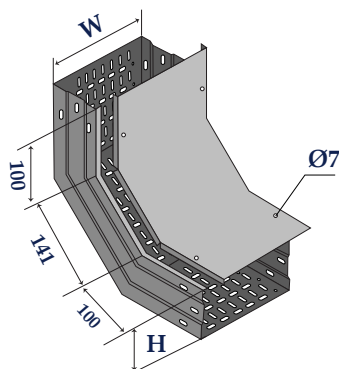

Co lên 90° - Internal riser 90°

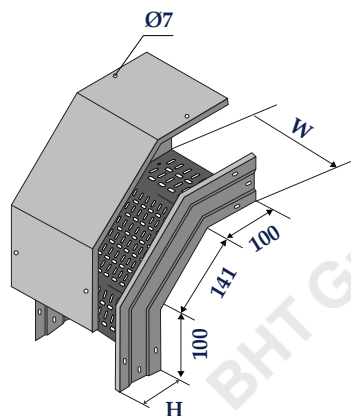

Co xuống 90° - External riser 90°

#### 1. Vật liệu / Material

- Thép tấm tráng kẽm (JIS 3302).
- Thép tấm đen (cán nóng, cán nguội).
- Thép tấm không gỉ SS304, SS316.
- Pre galvanized steel sheet (JIS 3302).
- Mild steel sheet (hot rolled, cold rolled).
- Stainless steel sheet 304,316.

#### 2. Hoàn thiện sản phẩm / Finish

- Bề mặt tự nhiên của vật liệu đối với sản phẩm tôn tráng kẽm, thép không gỉ.
- Mạ nhúng nóng.
- Sơn tĩnh điện
- Nature - protection for pre galvanized and stainless steel sheet.
- Hot dip galvanized - HDG.
- Power coated - PC

#### 3. Độ dài tiêu chuẩn / Standard length

3.0m/ thanh

3.0m/ length

#### Tên hàng Item

#### Rộng x Cao x Dày W x H x T

#### L Cable ladder, light duty

1.0 thickness	50 x 50 x 1.0 75 x (50,75) x 1.0	100 x (50,75,100) x 1.2
1.2 thickness		150 x (50,75,100) x 1.2
50mm high		200 x (50,75,100) x 1.2
75mm high		300 x (50,75,100) x 1.2
100mm high		400 x (50,75,100) x 1.2

#### M Cable ladder, medium duty

1.5 thickness	100 x (50, 75, 100) x 1.5
50mm high	200 x (50, 75, 100) x 1.5
75mm high	300 x (50, 75, 100) x 1.5
100mm high	400 x (50, 75, 100) x 1.5
	500 x (50, 75, 100) x 1.5
	600 x (50, 75, 100) x 1.5
	700 x (50, 75, 100) x 1.5
	800 x (50, 75, 100) x 1.5

#### H Cable ladder, heavy duty

2.0 thickness	200 x (75, 100, 125, 150) x 2.0
75mm high	300 x (75, 100, 125, 150) x 2.0
100mm high	400 x (75, 100, 125, 150) x 2.0
125mm high	500 x (75, 100, 125, 150) x 2.0
150mm high	600 x (75, 100, 125, 150) x 2.0
	700 x (75, 100, 125, 150) x 2.0
	800 x (75, 100, 125, 150) x 2.0
	900 x (75, 100, 125, 150) x 2.0
	1000 x (75, 100, 125, 150) x 2.0

#### F Cable ladder, fittings

- Bulong đầu dùi cổ vuông - Mushroom head square neck bolt M8 x12
- Long dẹt - Flat washer M8
- Con tán - Hex nut M8
- Miếng nối thang cáp - Ladder connector

#### Note: Material thickness: 1, 1.2, 1.5, 2.0

Xin xác định vật liệu khi gửi yêu cầu / Please confirm material on your request

Tôn tráng kẽm  
Pre galvanized steel

Mạ nhúng nóng - HDG  
Hot dip galvanized - HDG

Sơn tĩnh điện - PC  
Power coated - PC

Thép không gỉ  
Stainless steel

### 3. KHAY CÁP / Cable Tray

#### Co lên 45° / Co xuống 45° / Co chữ thập

Internal riser 45° / External riser 45° / Horizontal cross

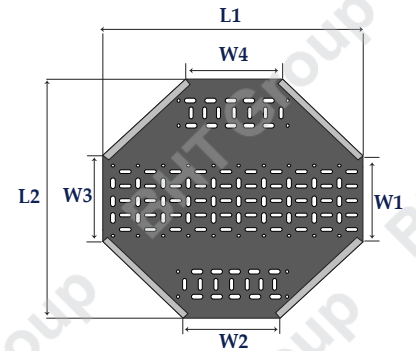
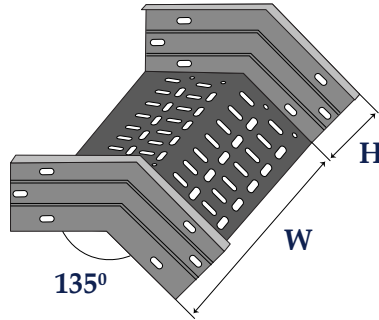
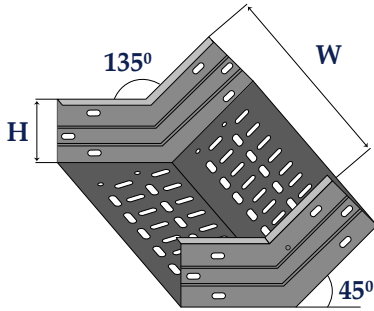

Co lên 45° - Internal riser 45°

Co xuống 45° - External riser 45°

Co chữ thập - Horizontal cross

#### 1. Vật liệu / Material

- Thép tấm tráng kẽm (JIS 3302).
- Thép tấm đen (cán nóng, cán nguội).
- Thép tấm không gỉ SS304, SS316.
- Pre galvanized steel sheet (JIS 3302).
- Mild steel sheet (hot rolled, cold rolled).
- Stainless steel sheet 304,316.

#### 2. Hoàn thiện sản phẩm / Finish

- Bề mặt tự nhiên của vật liệu đối với sản phẩm tôn tráng kẽm, thép không gỉ.
- Mạ nhúng nóng.
- Sơn tĩnh điện
- Nature - protection for pre galvanized and stainless steel sheet.
- Hot dip galvanized - HDG.
- Power coated - PC

#### 3. Độ dài tiêu chuẩn / Standard length

3.0m/ thanh

3.0m/ length

#### Tên hàng Item

#### Rộng x Cao x Dày W x H x T

#### L Cable ladder, light duty

1.0 thickness	50 x 50 x 1.0 75 x (50,75) x 1.0	100 x (50,75,100) x 1.2
1.2 thickness		150 x (50,75,100) x 1.2
50mm high		200 x (50,75,100) x 1.2
75mm high		300 x (50,75,100) x 1.2
100mm high		400 x (50,75,100) x 1.2

#### M Cable ladder, medium duty

	100 x (50, 75, 100) x 1.5
	200 x (50, 75, 100) x 1.5
1.5 thickness	300 x (50, 75, 100) x 1.5
50mm high	400 x (50, 75, 100) x 1.5
75mm high	500 x (50, 75, 100) x 1.5
100mm high	600 x (50, 75, 100) x 1.5
	700 x (50, 75, 100) x 1.5
	800 x (50, 75, 100) x 1.5

#### H Cable ladder, heavy duty

	200 x (75, 100, 125, 150) x 2.0
	300 x (75, 100, 125, 150) x 2.0
2.0 thickness	400 x (75, 100, 125, 150) x 2.0
75mm high	500 x (75, 100, 125, 150) x 2.0
100mm high	600 x (75, 100, 125, 150) x 2.0
125mm high	700 x (75, 100, 125, 150) x 2.0
150mm high	800 x (75, 100, 125, 150) x 2.0
	900 x (75, 100, 125, 150) x 2.0
	1000 x (75, 100, 125, 150) x 2.0

#### F Cable ladder, fittings

- Bulong đầu dẹt cổ vuông - Mushroom head square neck bolt M8 x12
- Long dẹt - Flat washer M8
- Con tán - Hex nut M8
- Miếng nối thang cáp - Ladder connector

#### Note: Material thickness: 1, 1.2, 1.5, 2.0

Xin xác định vật liệu khi gửi yêu cầu / Please confirm material on your request

Tôn tráng kẽm  
Pre galvanized steel

Mạ nhúng nóng - HDG  
Hot dip galvanized - HDG

Sơn tĩnh điện - PC  
Power coated - PC

Thép không gỉ  
Stainless steel

### 3. KHAY CÁP / Cable Tray

#### Co Z đứng / Co Z ngang phải/ Co Z ngang trái

Vertical Z / Right horizontal Z / Left horizontal Z

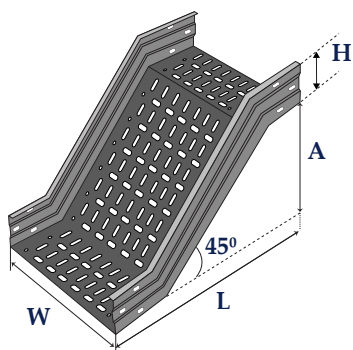

Co Z đứng - Vertical Z

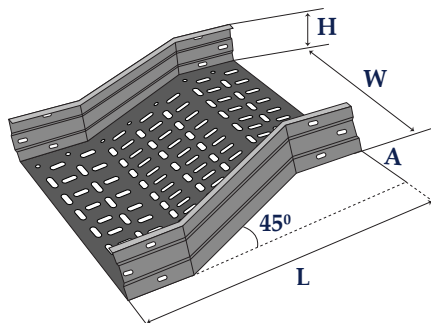

Co Z ngang phải - Right horizontal Z

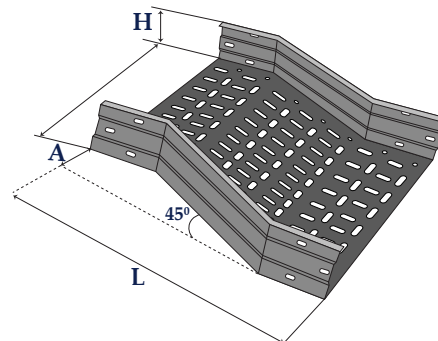

Co Z ngang trái - Left horizontal Z

#### 1. Vật liệu / Material

- Thép tấm tráng kẽm (JIS 3302).
- Thép tấm đen (cán nóng, cán nguội).
- Thép tấm không gỉ SS304, SS316.
- Pre galvanized steel sheet (JIS 3302).
- Mild steel sheet (hot rolled, cold rolled).
- Stainless steel sheet 304,316.

#### 2. Hoàn thiện sản phẩm / Finish

- Bề mặt tự nhiên của vật liệu đối với sản phẩm tôn tráng kẽm, thép không gỉ.
- Mạ nhúng nóng.
- Sơn tĩnh điện
- Nature - protection for pre galvanized and stainless steel sheet.
- Hot dip galvanized - HDG.
- Power coated - PC

#### 3. Độ dài tiêu chuẩn / Standard length

3.0m/ thanh

3.0m/ length

#### Tên hàng Item

#### Rộng x Cao x Dày W x H x T

#### L Cable ladder, light duty

1.0 thickness	50 x 50 x 1.0 75 x (50,75) x 1.0	100 x (50,75,100) x 1.2
1.2 thickness		150 x (50,75,100) x 1.2
50mm high		200 x (50,75,100) x 1.2
75mm high		300 x (50,75,100) x 1.2
100mm high		400 x (50,75,100) x 1.2

#### M Cable ladder, medium duty

1.5 thickness	100 x (50, 75, 100) x 1.5
50mm high	200 x (50, 75, 100) x 1.5
75mm high	300 x (50, 75, 100) x 1.5
100mm high	400 x (50, 75, 100) x 1.5
	500 x (50, 75, 100) x 1.5
	600 x (50, 75, 100) x 1.5
	700 x (50, 75, 100) x 1.5
	800 x (50, 75, 100) x 1.5

#### H Cable ladder, heavy duty

2.0 thickness	200 x (75, 100, 125, 150) x 2.0
75mm high	300 x (75, 100, 125, 150) x 2.0
100mm high	400 x (75, 100, 125, 150) x 2.0
125mm high	500 x (75, 100, 125, 150) x 2.0
150mm high	600 x (75, 100, 125, 150) x 2.0
	700 x (75, 100, 125, 150) x 2.0
	800 x (75, 100, 125, 150) x 2.0
	900 x (75, 100, 125, 150) x 2.0
	1000 x (75, 100, 125, 150) x 2.0

#### F Cable ladder, fittings

- Bulong đầu dẹt cổ vuông - Mushroom head square neck bolt M8 x12
- Long dẹt - Flat washer M8
- Con tán - Hex nut M8
- Miếng nối thang cáp - Ladder connector

#### Note: Material thickness: 1, 1.2, 1.5, 2.0

Xin xác định vật liệu khi gửi yêu cầu / Please confirm material on your request

Tôn tráng kẽm  
Pre galvanized steel

Mạ nhúng nóng - HDG  
Hot dip galvanized - HDG

Sơn tĩnh điện - PC  
Power coated - PC

Thép không gỉ  
Stainless steel

### 3. KHAY CÁP / Cable Tray

#### Co giảm phải / Co giảm trái / Co giảm giữa

Right reducer / Left reducer / Offset reducer

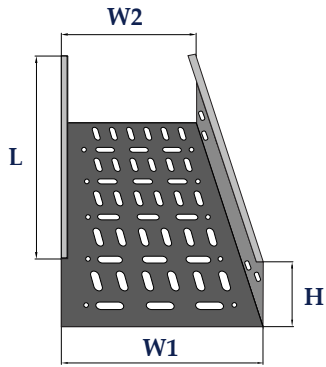

Co giảm phải - Right reducer

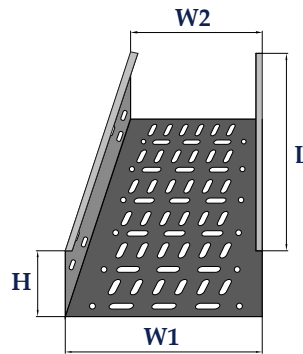

Co giảm trái - Left reducer

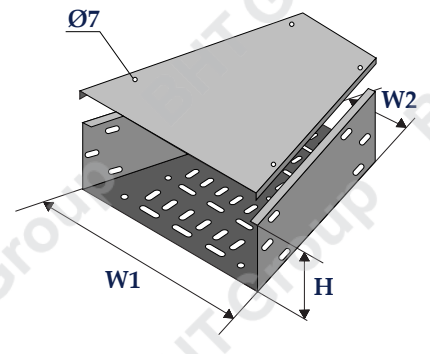

Co giảm giữa - Offset reducer

#### 1. Vật liệu / Material

- Thép tấm tráng kẽm (JIS 3302).
- Thép tấm đen (cán nóng, cán nguội).
- Thép tấm không gỉ SS304, SS316.
- Pre galvanized steel sheet (JIS 3302).
- Mild steel sheet (hot rolled, cold rolled).
- Stainless steel sheet 304,316.

#### 2. Hoàn thiện sản phẩm / Finish

- Bề mặt tự nhiên của vật liệu đối với sản phẩm tôn tráng kẽm, thép không gỉ.
- Mạ nhúng nóng.
- Sơn tĩnh điện
- Nature - protection for pre galvanized and stainless steel sheet.
- Hot dip galvanized - HDG.
- Power coated - PC

#### 3. Độ dài tiêu chuẩn / Standard length

3.0m/ thanh

3.0m/ length

#### Tên hàng Item

#### Rộng x Cao x Dày W x H x T

#### L Cable ladder, light duty

Item	W x H x T	Dimensions
1.0 thickness	50 x 50 x 1.0 75 x (50,75) x 1.0	100 x (50,75,100) x 1.2
1.2 thickness		150 x (50,75,100) x 1.2
50mm high		200 x (50,75,100) x 1.2
75mm high		300 x (50,75,100) x 1.2
100mm high		400 x (50,75,100) x 1.2

#### M Cable ladder, medium duty

Item	Dimensions
1.5 thickness	100 x (50, 75, 100) x 1.5
50mm high	200 x (50, 75, 100) x 1.5
75mm high	300 x (50, 75, 100) x 1.5
100mm high	400 x (50, 75, 100) x 1.5
	500 x (50, 75, 100) x 1.5
	600 x (50, 75, 100) x 1.5
	700 x (50, 75, 100) x 1.5
	800 x (50, 75, 100) x 1.5

#### H Cable ladder, heavy duty

Item	Dimensions
2.0 thickness	200 x (75, 100, 125, 150) x 2.0
75mm high	300 x (75, 100, 125, 150) x 2.0
100mm high	400 x (75, 100, 125, 150) x 2.0
125mm high	500 x (75, 100, 125, 150) x 2.0
150mm high	600 x (75, 100, 125, 150) x 2.0
	700 x (75, 100, 125, 150) x 2.0
	800 x (75, 100, 125, 150) x 2.0
	900 x (75, 100, 125, 150) x 2.0
	1000 x (75, 100, 125, 150) x 2.0

#### F Cable ladder, fittings

Bulong đầu dùi cổ vuông - Mushroom head square neck bolt M8 x12

Long dẹt - Flat washer M8

Con tán - Hex nut M8

Miếng nối thang cáp - Ladder connector

#### Note: Material thickness: 1, 1.2, 1.5, 2.0

Xin xác định vật liệu khi gửi yêu cầu / Please confirm material on your request

Tôn tráng kẽm  
Pre galvanized steel

Mạ nhúng nóng - HDG  
Hot dip galvanized - HDG

Sơn tĩnh điện - PC  
Power coated - PC

Thép không gỉ  
Stainless steel

Khay cáp có gân - Ribbed cable tray

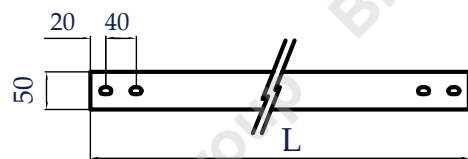
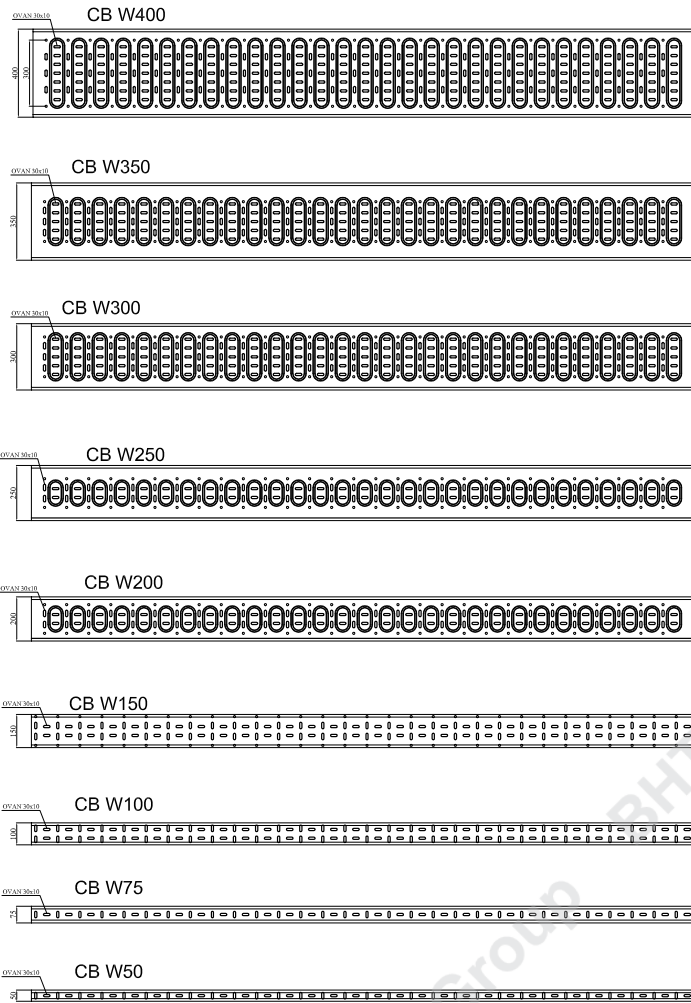

WxH50xL

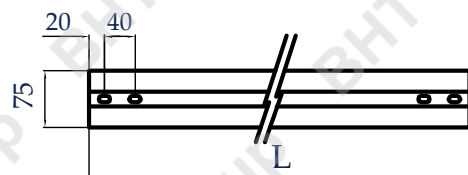

WxH50xL

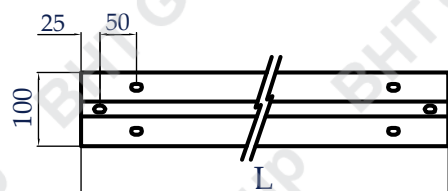

WxH50xL

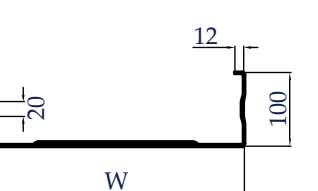
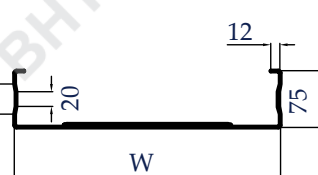

Khay cáp không có gân - Cable tray without ribs

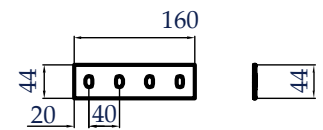
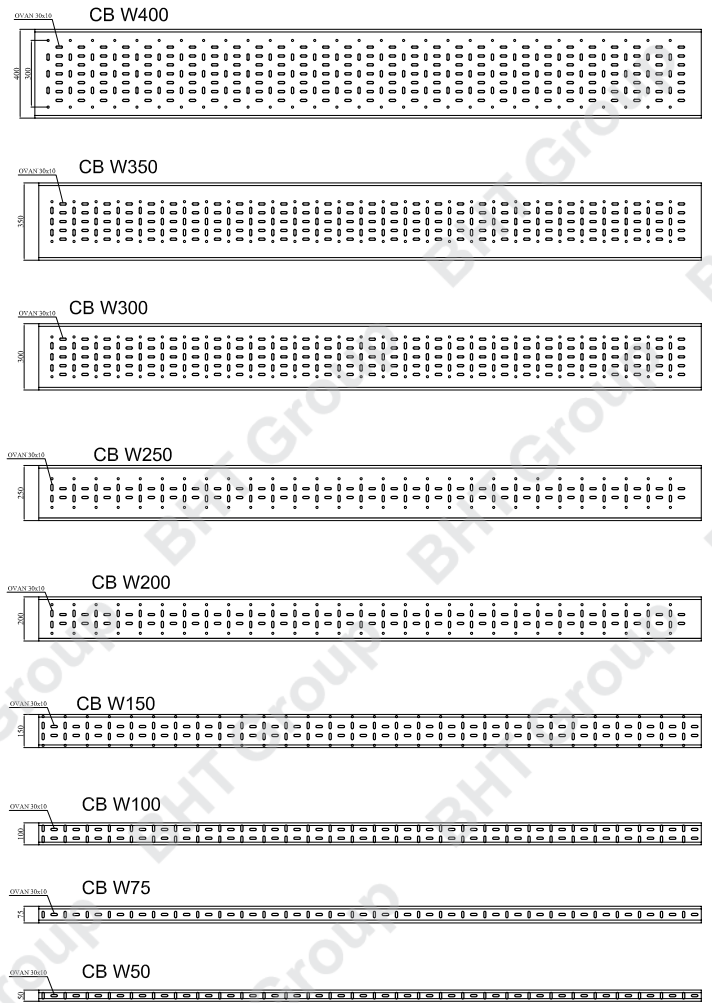

PASS NỐI H = 50mm

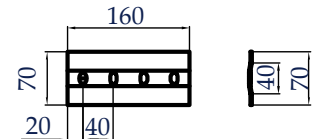

PASS NỐI H = 75mm

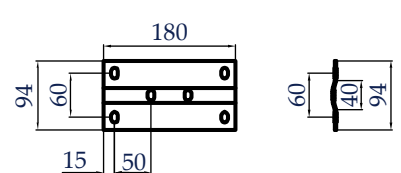

PASS NỐI H = 100mm

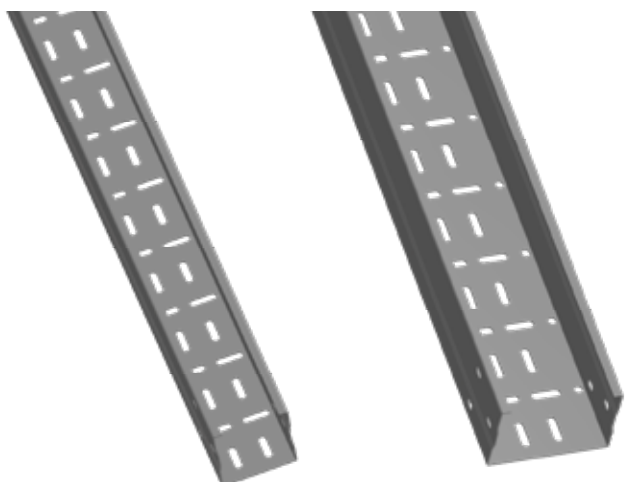

W100xH100

W150xH100

### 1. Tiêu chuẩn / Standard

- H75, H100 có gân cạnh
- $H \geq 200$  có gân bụng
- *H75, H100 have ribbed edges*
- *$H \geq 200$  has abdominal veins*

### 2. Vật liệu / Material

- Inox không gân cạnh, không gân bụng
- Zam không gân cạnh, không gân bụng
- *Inox has no side ribs, no belly ribs*
- *Zam has no side ribs, no belly ribs*

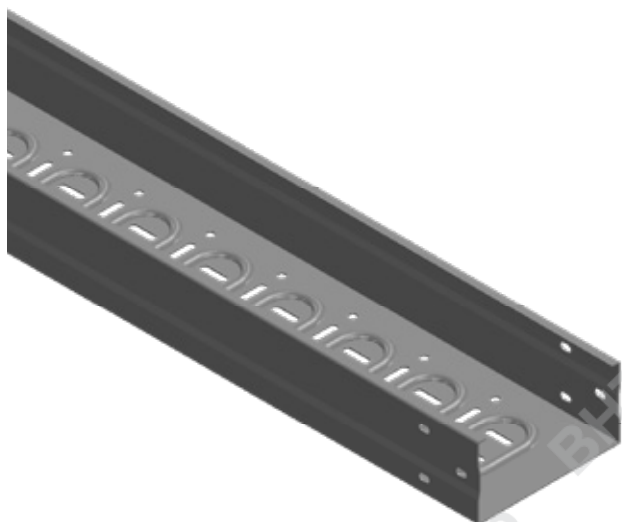

W200xH100

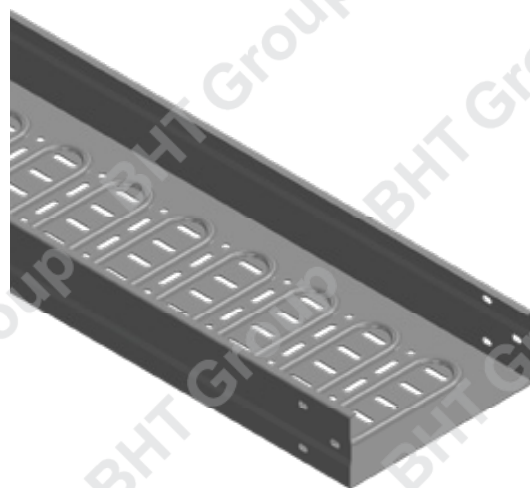

W300xH100

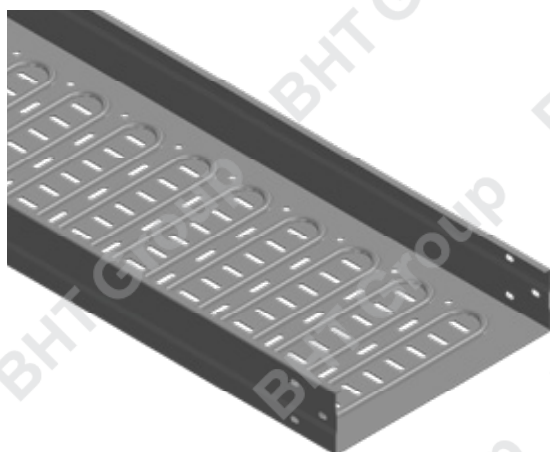

W400xH100

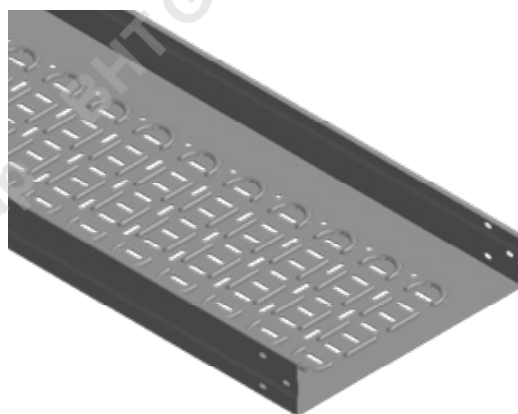

W500xH100

## 4. MÁNG CÁP / Cable Trunking

### Thanh thẳng / Straight ladder

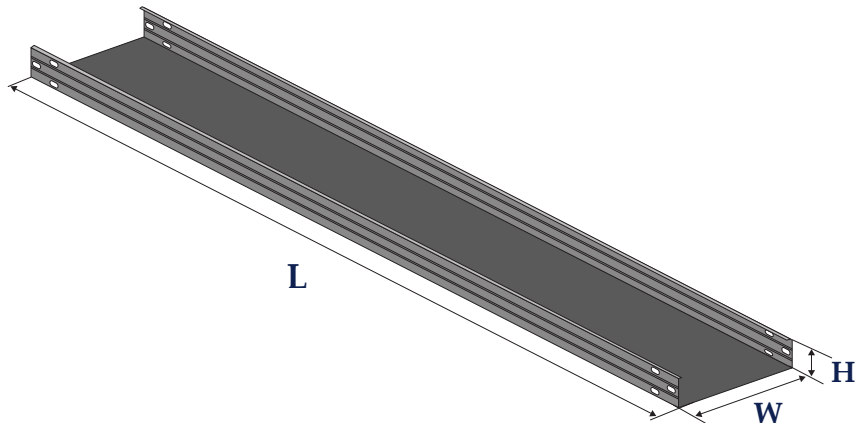
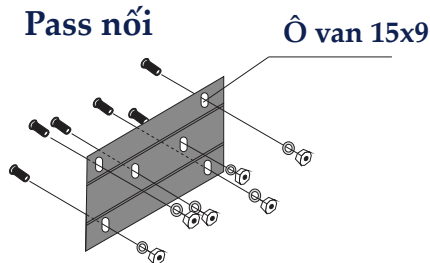

#### 1. Vật liệu / Material

- Thép tấm tráng kẽm (JIS 3302).
- Thép tấm đen (cán nóng, cán nguội).
- Thép tấm không gỉ SS304, SS316.
- Pre galvanized steel sheet (JIS 3302).
- Mild steel sheet (hot rolled, cold rolled).
- Stainless steel sheet 304,316.

#### 2. Hoàn thiện sản phẩm / Finish

- Bề mặt tự nhiên của vật liệu đối với sản phẩm tôn tráng kẽm, thép không gỉ.
- Mạ nhúng nóng.
- Sơn tĩnh điện
- Nature - protection for pre galvanized and stainless steel sheet.
- Hot dip galvanized - HDG.
- Power coated - PC

#### 3. Độ dài tiêu chuẩn / Standard length

3.0m/ thanh

3.0m/ length

#### Tên hàng Item

#### Rộng x Cao x Dày W x H x T

#### L Cable ladder, light duty

1.0 thickness	50 x 50 x 1.0 75 x (50,75) x 1.0	100 x (50,75,100) x 1.2
1.2 thickness		150 x (50,75,100) x 1.2
50mm high		200 x (50,75,100) x 1.2
75mm high		300 x (50,75,100) x 1.2
100mm high		400 x (50,75,100) x 1.2

#### M Cable ladder, medium duty

1.5 thickness	100 x (50, 75, 100) x 1.5
50mm high	200 x (50, 75, 100) x 1.5
75mm high	300 x (50, 75, 100) x 1.5
100mm high	400 x (50, 75, 100) x 1.5
	500 x (50, 75, 100) x 1.5
	600 x (50, 75, 100) x 1.5
	700 x (50, 75, 100) x 1.5
	800 x (50, 75, 100) x 1.5

#### H Cable ladder, heavy duty

2.0 thickness	200 x (75, 100, 125, 150) x 2.0
75mm high	300 x (75, 100, 125, 150) x 2.0
100mm high	400 x (75, 100, 125, 150) x 2.0
125mm high	500 x (75, 100, 125, 150) x 2.0
150mm high	600 x (75, 100, 125, 150) x 2.0
	700 x (75, 100, 125, 150) x 2.0
	800 x (75, 100, 125, 150) x 2.0
	900 x (75, 100, 125, 150) x 2.0
	1000 x (75, 100, 125, 150) x 2.0

#### F Cable ladder, fittings

- Bulong đầu dùi cổ vuông - Mushroom head square neck bolt M8 x12
- Long dẹt - Flat washer M8
- Con tán - Hex nut M8
- Miếng nối thang cáp - Ladder connector

#### Note: Material thickness: 1, 1.2, 1.5, 2.0

Xin xác định vật liệu khi gửi yêu cầu / Please confirm material on your request

Tôn tráng kẽm  
Pre galvanized steel

Mạ nhúng nóng - HDG  
Hot dip galvanized - HDG

Sơn tĩnh điện - PC  
Power coated - PC

Thép không gỉ  
Stainless steel

## 4. MÁNG CÁP / Cable Trunking

### Co ngang 90° / Co ngang 45° / Co chữ T

Horizontal elbow 90° / Horizontal elbow 45° / Horizontal T

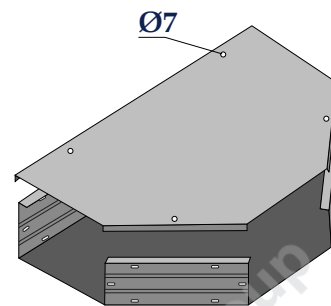
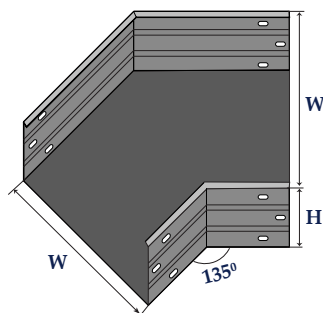
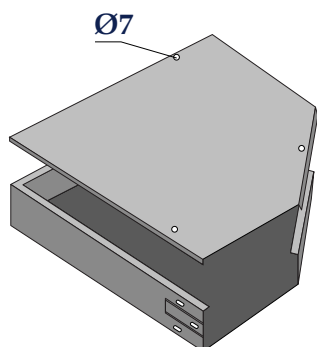

Co ngang 90° - Horizontal elbow 90°

Co ngang 45° - Horizontal elbow 45°

Co chữ T - Horizontal T

#### 1. Vật liệu / Material

- Thép tấm tráng kẽm (JIS 3302).
- Thép tấm đen (cán nóng, cán nguội).
- Thép tấm không gỉ SS304, SS316.
- Pre galvanized steel sheet (JIS 3302).
- Mild steel sheet (hot rolled, cold rolled).
- Stainless steel sheet 304,316.

#### 2. Hoàn thiện sản phẩm / Finish

- Bề mặt tự nhiên của vật liệu đối với sản phẩm tôn tráng kẽm, thép không gỉ.
- Mạ nhúng nóng.
- Sơn tĩnh điện
- Nature - protection for pre galvanized and stainless steel sheet.
- Hot dip galvanized - HDG.
- Power coated - PC

#### 3. Độ dài tiêu chuẩn / Standard length

3.0m/ thanh

3.0m/ length

#### Tên hàng Item

#### Rộng x Cao x Dày W x H x T

#### L Cable ladder, light duty

1.0 thickness	50 x 50 x 1.0 75 x (50,75) x 1.0	100 x (50,75,100) x 1.2
1.2 thickness		150 x (50,75,100) x 1.2
50mm high		200 x (50,75,100) x 1.2
75mm high		300 x (50,75,100) x 1.2
100mm high		400 x (50,75,100) x 1.2

#### M Cable ladder, medium duty

1.5 thickness	100 x (50, 75, 100) x 1.5 200 x (50, 75, 100) x 1.5 300 x (50, 75, 100) x 1.5 400 x (50, 75, 100) x 1.5 500 x (50, 75, 100) x 1.5 600 x (50, 75, 100) x 1.5 700 x (50, 75, 100) x 1.5 800 x (50, 75, 100) x 1.5
50mm high	
75mm high	
100mm high	

#### H Cable ladder, heavy duty

2.0 thickness	200 x (75, 100, 125, 150) x 2.0 300 x (75, 100, 125, 150) x 2.0 400 x (75, 100, 125, 150) x 2.0 500 x (75, 100, 125, 150) x 2.0 600 x (75, 100, 125, 150) x 2.0 700 x (75, 100, 125, 150) x 2.0 800 x (75, 100, 125, 150) x 2.0 900 x (75, 100, 125, 150) x 2.0 1000 x (75, 100, 125, 150) x 2.0
75mm high	
100mm high	
125mm high	
150mm high	

#### F Cable ladder, fittings

- Bulong đầu dùi cổ vuông - Mushroom head square neck bolt M8 x12
- Long dẹt - Flat washer M8
- Con tán - Hex nut M8
- Miếng nối thang cáp - Ladder connector

#### Note: Material thickness: 1, 1.2, 1.5, 2.0

Xin xác định vật liệu khi gửi yêu cầu / Please confirm material on your request

Tôn tráng kẽm  
Pre galvanized steel

Mạ nhúng nóng - HDG  
Hot dip galvanized - HDG

Sơn tĩnh điện - PC  
Power coated - PC

Thép không gỉ  
Stainless steel

## 4. MÁNG CÁP / Cable Trunking

### Co T đứng trục ngang / Co T đứng trục dọc

T Shaped Hinge Horizontal / T Shaped Hinge Vertical

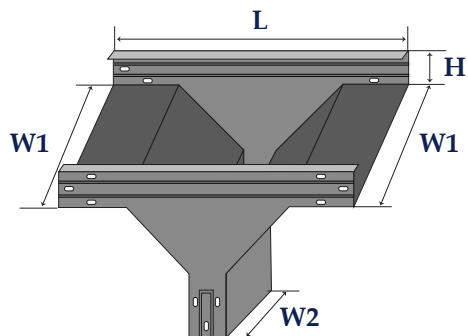

Co T đứng trục ngang - T shaped hinge horizontal

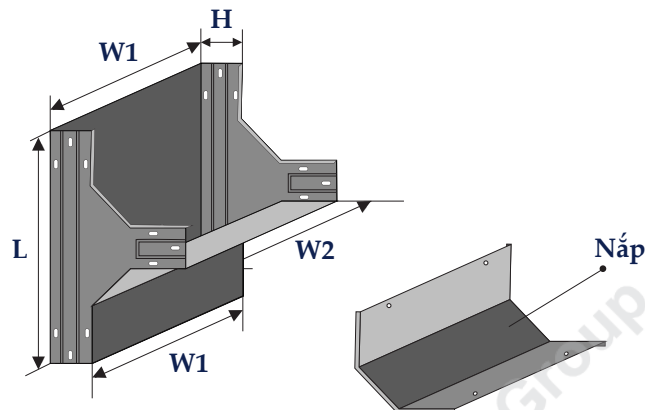

Co T đứng trục dọc - T shaped hinge vertical

#### 1. Vật liệu / Material

- Thép tấm tráng kẽm (JIS 3302).
- Thép tấm đen (cán nóng, cán nguội).
- Thép tấm không gỉ SS304, SS316.
- Pre galvanized steel sheet (JIS 3302).
- Mild steel sheet (hot rolled, cold rolled).
- Stainless steel sheet 304,316.

#### 2. Hoàn thiện sản phẩm / Finish

- Bề mặt tự nhiên của vật liệu đối với sản phẩm tôn tráng kẽm, thép không gỉ.
- Mạ nhúng nóng.
- Sơn tĩnh điện
- Nature - protection for pre galvanized and stainless steel sheet.
- Hot dip galvanized - HDG.
- Power coated - PC

#### 3. Độ dài tiêu chuẩn / Standard length

3.0m/ thanh

3.0m/ length

#### Note: Material thickness: 1, 1.2, 1.5, 2.0

Xin xác định vật liệu khi gửi yêu cầu / Please confirm material on your request

Tôn tráng kẽm  
Pre galvanized steel

Mạ nhúng nóng - HDG  
Hot dip galvanized - HDG

Sơn tĩnh điện - PC  
Power coated - PC

Thép không gỉ  
Stainless steel

#### Tên hàng Item

#### Rộng x Cao x Dày W x H x T

#### L Cable ladder, light duty

1.0 thickness	50 x 50 x 1.0 75 x (50,75) x 1.0	100 x (50,75,100) x 1.2
1.2 thickness		150 x (50,75,100) x 1.2
50mm high		200 x (50,75,100) x 1.2
75mm high		300 x (50,75,100) x 1.2
100mm high		400 x (50,75,100) x 1.2

#### M Cable ladder, medium duty

1.5 thickness 50mm high 75mm high 100mm high	100 x (50, 75, 100) x 1.5
	200 x (50, 75, 100) x 1.5
	300 x (50, 75, 100) x 1.5
	400 x (50, 75, 100) x 1.5
	500 x (50, 75, 100) x 1.5
	600 x (50, 75, 100) x 1.5
	700 x (50, 75, 100) x 1.5
800 x (50, 75, 100) x 1.5	

#### H Cable ladder, heavy duty

2.0 thickness 75mm high 100mm high 125mm high 150mm high	200 x (75, 100, 125, 150) x 2.0
	300 x (75, 100, 125, 150) x 2.0
	400 x (75, 100, 125, 150) x 2.0
	500 x (75, 100, 125, 150) x 2.0
	600 x (75, 100, 125, 150) x 2.0
	700 x (75, 100, 125, 150) x 2.0
	800 x (75, 100, 125, 150) x 2.0
900 x (75, 100, 125, 150) x 2.0	
1000 x (75, 100, 125, 150) x 2.0	

#### F Cable ladder, fittings

- Bulong đầu dẹt cổ vuông - Mushroom head square neck bolt M8 x12
- Long dẹt - Flat washer M8
- Con tán - Hex nut M8
- Miếng nối thang cáp - Ladder connector

## 4. MÁNG CÁP / Cable Trunking

### Co lên 90° / Co xuống 90°

Internal Riser 90° / External Riser 90°

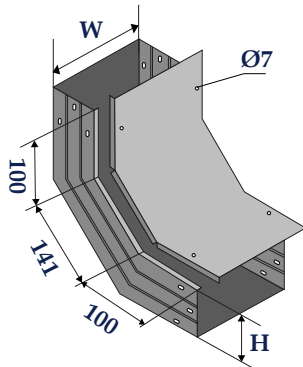

Co lên 90° - Internal riser 90°

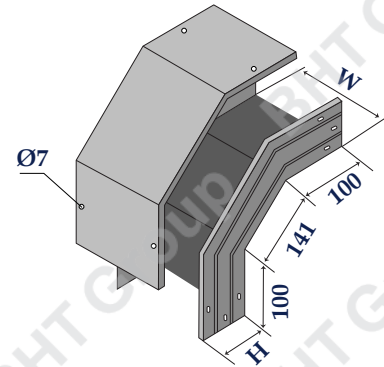

Co xuống 90° - External riser 90°

#### 1. Vật liệu / Material

- Thép tấm tráng kẽm (JIS 3302).
- Thép tấm đen (cán nóng, cán nguội).
- Thép tấm không gỉ SS304, SS316.
- Pre galvanized steel sheet (JIS 3302).
- Mild steel sheet (hot rolled, cold rolled).
- Stainless steel sheet 304,316.

#### 2. Hoàn thiện sản phẩm / Finish

- Bề mặt tự nhiên của vật liệu đối với sản phẩm tôn tráng kẽm, thép không gỉ.
- Mạ nhúng nóng.
- Sơn tĩnh điện
- Nature - protection for pre galvanized and stainless steel sheet.
- Hot dip galvanized - HDG.
- Power coated - PC

#### 3. Độ dài tiêu chuẩn / Standard length

3.0m/ thanh

3.0m/ length

#### Tên hàng Item

#### Rộng x Cao x Dày W x H x T

#### L Cable ladder, light duty

1.0 thickness	50 x 50 x 1.0 75 x (50,75) x 1.0	100 x (50,75,100) x 1.2
1.2 thickness		150 x (50,75,100) x 1.2
50mm high		200 x (50,75,100) x 1.2
75mm high		300 x (50,75,100) x 1.2
100mm high		400 x (50,75,100) x 1.2

#### M Cable ladder, medium duty

1.5 thickness 50mm high 75mm high 100mm high	100 x (50, 75, 100) x 1.5
	200 x (50, 75, 100) x 1.5
	300 x (50, 75, 100) x 1.5
	400 x (50, 75, 100) x 1.5
	500 x (50, 75, 100) x 1.5
	600 x (50, 75, 100) x 1.5
700 x (50, 75, 100) x 1.5	
800 x (50, 75, 100) x 1.5	

#### H Cable ladder, heavy duty

2.0 thickness 75mm high 100mm high 125mm high 150mm high	200 x (75, 100, 125, 150) x 2.0
	300 x (75, 100, 125, 150) x 2.0
	400 x (75, 100, 125, 150) x 2.0
	500 x (75, 100, 125, 150) x 2.0
	600 x (75, 100, 125, 150) x 2.0
	700 x (75, 100, 125, 150) x 2.0
	800 x (75, 100, 125, 150) x 2.0
	900 x (75, 100, 125, 150) x 2.0
1000 x (75, 100, 125, 150) x 2.0	

#### F Cable ladder, fittings

Bulong đầu dẹt cổ vuông - Mushroom head square neck bolt M8 x12

Long dẹt - Flat washer M8

Con tán - Hex nut M8

Miếng nối thang cáp - Ladder connector

#### • Note: Material thickness: 1, 1.2, 1.5, 2.0

Xin xác định vật liệu khi gửi yêu cầu / Please confirm material on your request

Tôn tráng kẽm  
Pre galvanized steel

Mạ nhúng nóng - HDG  
Hot dip galvanized - HDG

Sơn tĩnh điện - PC  
Power coated - PC

Thép không gỉ  
Stainless steel

## 4. MÁNG CÁP / Cable Trunking

### Co lên 45° / Co xuống 45° / Co chữ thập

Internal Riser 45° / External Riser 45° / Horizontal Cross

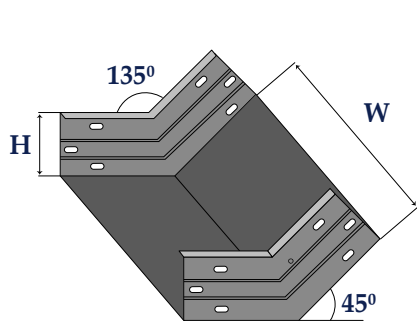

Co lên 45° - Internal riser 45°

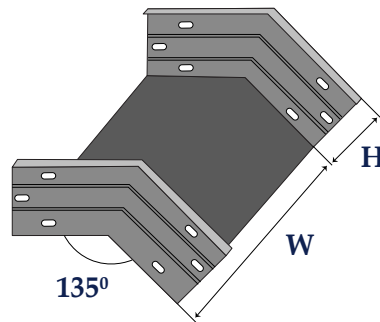

Co xuống 45° - External riser 45°

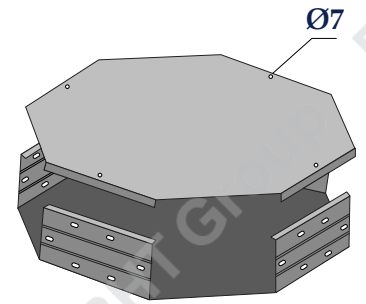

Co chữ thập - Horizontal cross

#### 1. Vật liệu / Material

- Thép tấm tráng kẽm (JIS 3302).
- Thép tấm đen (cán nóng, cán nguội).
- Thép tấm không gỉ SS304, SS316.
- Pre galvanized steel sheet (JIS 3302).
- Mild steel sheet (hot rolled, cold rolled).
- Stainless steel sheet 304,316.

#### 2. Hoàn thiện sản phẩm / Finish

- Bề mặt tự nhiên của vật liệu đối với sản phẩm tôn tráng kẽm, thép không gỉ.
- Mạ nhúng nóng.
- Sơn tĩnh điện
- Nature - protection for pre galvanized and stainless steel sheet.
- Hot dip galvanized - HDG.
- Power coated - PC

#### 3. Độ dài tiêu chuẩn / Standard length

3.0m/ thanh

3.0m/ length

#### Tên hàng Item

#### Rộng x Cao x Dày W x H x T

#### L Cable ladder, light duty

1.0 thickness	50 x 50 x 1.0 75 x (50,75) x 1.0	100 x (50,75,100) x 1.2
1.2 thickness		150 x (50,75,100) x 1.2
50mm high		200 x (50,75,100) x 1.2
75mm high		300 x (50,75,100) x 1.2
100mm high		400 x (50,75,100) x 1.2

#### M Cable ladder, medium duty

1.5 thickness	100 x (50, 75, 100) x 1.5
50mm high	200 x (50, 75, 100) x 1.5
75mm high	300 x (50, 75, 100) x 1.5
100mm high	400 x (50, 75, 100) x 1.5
	500 x (50, 75, 100) x 1.5
	600 x (50, 75, 100) x 1.5
	700 x (50, 75, 100) x 1.5
	800 x (50, 75, 100) x 1.5

#### H Cable ladder, heavy duty

2.0 thickness	200 x (75, 100, 125, 150) x 2.0
75mm high	300 x (75, 100, 125, 150) x 2.0
100mm high	400 x (75, 100, 125, 150) x 2.0
125mm high	500 x (75, 100, 125, 150) x 2.0
150mm high	600 x (75, 100, 125, 150) x 2.0
	700 x (75, 100, 125, 150) x 2.0
	800 x (75, 100, 125, 150) x 2.0
	900 x (75, 100, 125, 150) x 2.0
	1000 x (75, 100, 125, 150) x 2.0

#### F Cable ladder, fittings

Bulong đầu dùi cổ vuông - Mushroom head square neck bolt M8 x12

Long dẹt - Flat washer M8

Con tán - Hex nut M8

Miếng nối thang cáp - Ladder connector

#### Note: Material thickness: 1, 1.2, 1.5, 2.0

Xin xác định vật liệu khi gửi yêu cầu / Please confirm material on your request

Tôn tráng kẽm  
Pre galvanized steel

Mạ nhúng nóng - HDG  
Hot dip galvanized - HDG

Sơn tĩnh điện - PC  
Power coated - PC

Thép không gỉ  
Stainless steel

## 4. MÁNG CÁP / Cable Trunking

### Co Z đứng / Co Z ngang phải/ Co Z ngang trái

Vertical Z / Right horizontal Z / Left horizontal Z

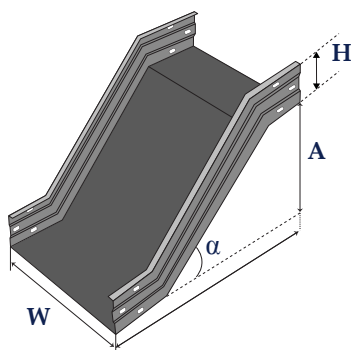

Co Z đứng - Vertical Z

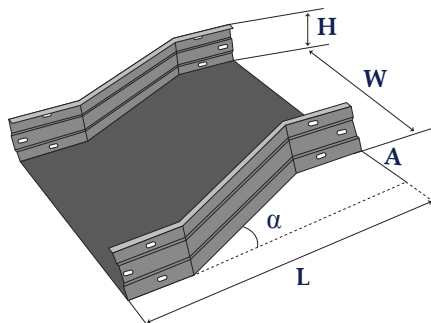

Co Z ngang phải - Right horizontal Z

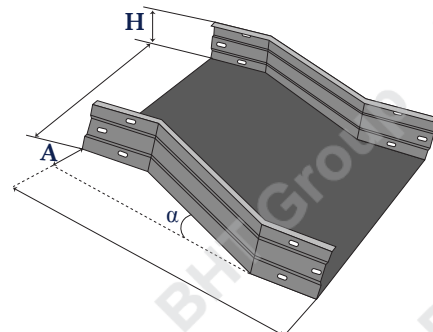

Co Z ngang trái - Left horizontal Z

#### 1. Vật liệu / Material

- Thép tấm tráng kẽm (JIS 3302).
- Thép tấm đen (cán nóng, cán nguội).
- Thép tấm không gỉ SS304, SS316.
- Pre galvanized steel sheet (JIS 3302).
- Mild steel sheet (hot rolled, cold rolled).
- Stainless steel sheet 304,316.

#### 2. Hoàn thiện sản phẩm / Finish

- Bề mặt tự nhiên của vật liệu đối với sản phẩm tôn tráng kẽm, thép không gỉ.
- Mạ nhúng nóng.
- Sơn tĩnh điện
- Nature - protection for pre galvanized and stainless steel sheet.
- Hot dip galvanized - HDG.
- Power coated - PC

#### 3. Độ dài tiêu chuẩn / Standard length

3.0m/ thanh

3.0m/ length

#### Tên hàng Item

#### Rộng x Cao x Dày W x H x T

#### L Cable ladder, light duty

1.0 thickness	50 x 50 x 1.0 75 x (50,75) x 1.0	100 x (50,75,100) x 1.2
1.2 thickness		150 x (50,75,100) x 1.2
50mm high		200 x (50,75,100) x 1.2
75mm high		300 x (50,75,100) x 1.2
100mm high		400 x (50,75,100) x 1.2

#### M Cable ladder, medium duty

1.5 thickness	100 x (50, 75, 100) x 1.5
50mm high	200 x (50, 75, 100) x 1.5
75mm high	300 x (50, 75, 100) x 1.5
100mm high	400 x (50, 75, 100) x 1.5
	500 x (50, 75, 100) x 1.5
	600 x (50, 75, 100) x 1.5
	700 x (50, 75, 100) x 1.5
	800 x (50, 75, 100) x 1.5

#### H Cable ladder, heavy duty

2.0 thickness	200 x (75, 100, 125, 150) x 2.0
75mm high	300 x (75, 100, 125, 150) x 2.0
100mm high	400 x (75, 100, 125, 150) x 2.0
125mm high	500 x (75, 100, 125, 150) x 2.0
150mm high	600 x (75, 100, 125, 150) x 2.0
	700 x (75, 100, 125, 150) x 2.0
	800 x (75, 100, 125, 150) x 2.0
	900 x (75, 100, 125, 150) x 2.0
	1000 x (75, 100, 125, 150) x 2.0

#### F Cable ladder, fittings

- Bulong đầu dẹt cổ vuông - Mushroom head square neck bolt M8 x12
- Long dẹt - Flat washer M8
- Con tán - Hex nut M8
- Miếng nối thang cáp - Ladder connector

#### Note: Material thickness: 1, 1.2, 1.5, 2.0

Xin xác định vật liệu khi gửi yêu cầu / Please confirm material on your request

Tôn tráng kẽm  
Pre galvanized steel

Mạ nhúng nóng - HDG  
Hot dip galvanized - HDG

Sơn tĩnh điện - PC  
Power coated - PC

Thép không gỉ  
Stainless steel

## 4. MÁNG CÁP / Cable Trunking

### Co giảm phải / Co giảm trái / Co giảm giữa

Right reducer / Left reducer / Offset reducer

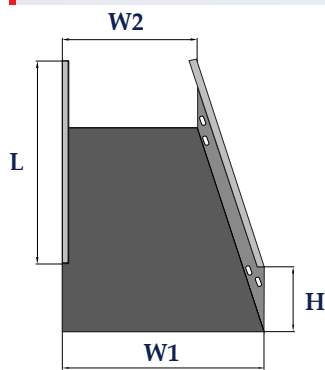

Co giảm phải - Right reducer

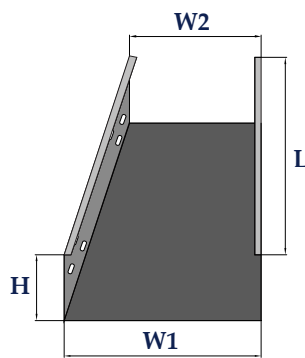

Co giảm trái - Left reducer

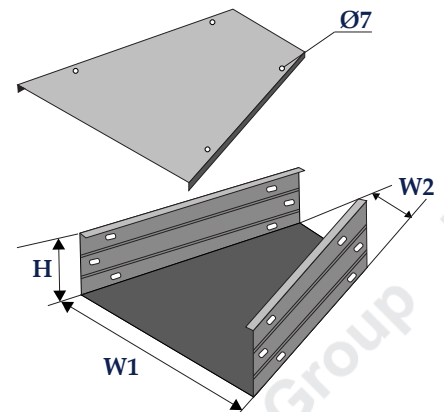

Co giảm giữa - Offset reducer

### 1. Vật liệu / Material

- Thép tấm tráng kẽm (JIS 3302).
- Thép tấm đen (cán nóng, cán nguội).
- Thép tấm không gỉ SS304, SS316.
- Pre galvanized steel sheet (JIS 3302).
- Mild steel sheet (hot rolled, cold rolled).
- Stainless steel sheet 304,316.

### 2. Hoàn thiện sản phẩm / Finish

- Bề mặt tự nhiên của vật liệu đối với sản phẩm tôn tráng kẽm, thép không gỉ.
- Mạ nhúng nóng.
- Sơn tĩnh điện
- Nature - protection for pre galvanized and stainless steel sheet.
- Hot dip galvanized - HDG.
- Power coated - PC

### 3. Độ dài tiêu chuẩn / Standard length

3.0m/ thanh

3.0m/ length

### Tên hàng Item

### Rộng x Cao x Dày W x H x T

#### L Cable ladder, light duty

1.0 thickness	50 x 50 x 1.0 75 x (50,75) x 1.0	100 x (50,75,100) x 1.2
1.2 thickness		150 x (50,75,100) x 1.2
50mm high		200 x (50,75,100) x 1.2
75mm high		300 x (50,75,100) x 1.2
100mm high		400 x (50,75,100) x 1.2

#### M Cable ladder, medium duty

1.5 thickness 50mm high 75mm high 100mm high	100 x (50, 75, 100) x 1.5
	200 x (50, 75, 100) x 1.5
	300 x (50, 75, 100) x 1.5
	400 x (50, 75, 100) x 1.5
	500 x (50, 75, 100) x 1.5
	600 x (50, 75, 100) x 1.5
	700 x (50, 75, 100) x 1.5
800 x (50, 75, 100) x 1.5	

#### H Cable ladder, heavy duty

2.0 thickness 75mm high 100mm high 125mm high 150mm high	200 x (75, 100, 125, 150) x 2.0
	300 x (75, 100, 125, 150) x 2.0
	400 x (75, 100, 125, 150) x 2.0
	500 x (75, 100, 125, 150) x 2.0
	600 x (75, 100, 125, 150) x 2.0
	700 x (75, 100, 125, 150) x 2.0
	800 x (75, 100, 125, 150) x 2.0
900 x (75, 100, 125, 150) x 2.0	
1000 x (75, 100, 125, 150) x 2.0	

#### F Cable ladder, fittings

- Bulông đầu dùi cổ vuông - Mushroom head square neck bolt M8 x12
- Long dẹt - Flat washer M8
- Con tán - Hex nut M8
- Miếng nối thang cáp - Ladder connector

### • Note: Material thickness: 1, 1.2, 1.5, 2.0

Xin xác định vật liệu khi gửi yêu cầu / Please confirm material on your request

Tôn tráng kẽm  
Pre galvanized steel

Mạ nhúng nóng - HDG  
Hot dip galvanized - HDG

Sơn tĩnh điện - PC  
Power coated - PC

Thép không gỉ  
Stainless steel

• **Kích thước:**

- H50 không có gân cạnh
- H75, H100 có gân cạnh

• **Vật liệu:**

- Inox không gân cạnh, không gân bụng
- Zam không gân cạnh, không gân bụng

• **Standard**

- H50 No edge ribs
- H75, H100 have ribbed edges

• **Material**

- Inox has no side ribs
- Zam has no side ribs

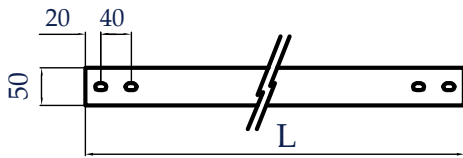

WxH50xL

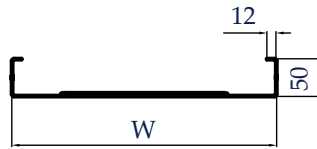

W

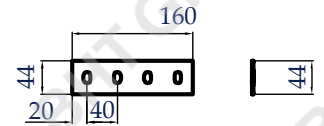

PASS NỐI H = 50mm

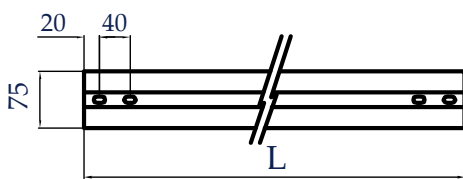

WxH50xL

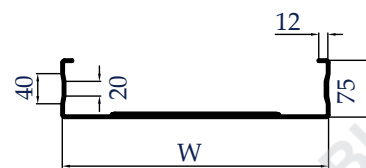

W

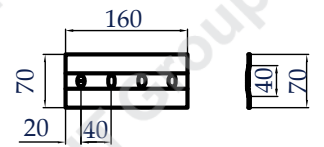

PASS NỐI H = 75mm

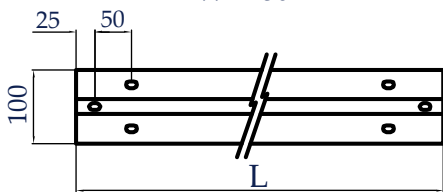

WxH50xL

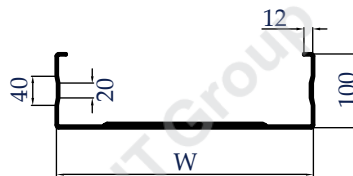

W

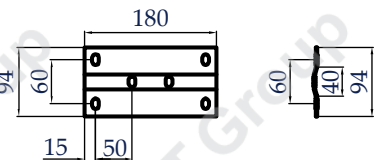

PASS NỐI H = 100mm

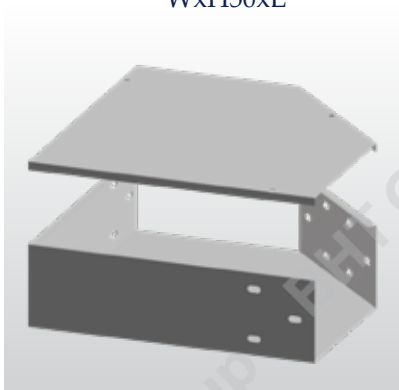

Co ngang 90°  
Horizontal elbow 90°



Co chữ T  
Horizontal Tee

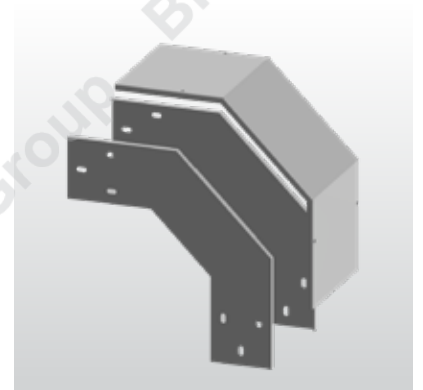

Co xuống 90°  
External Riser 90°

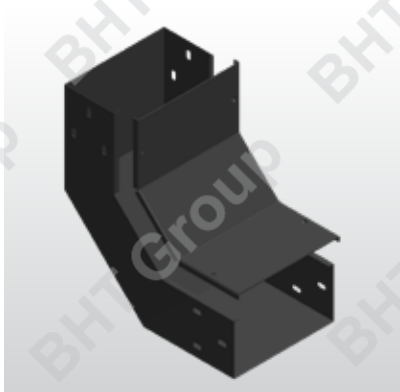

Co lên 90°  
Internal Riser 90°



Co chữ thập  
Horizontal Cross



Co ngang giảm  
Offset reducer

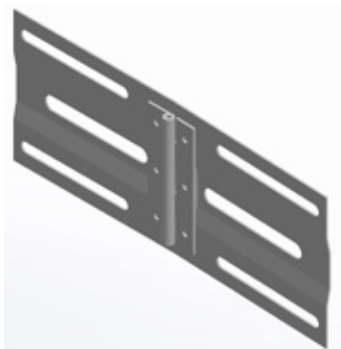

Nối xoay ngang ngoài  
Connector for outer horizontal hinge

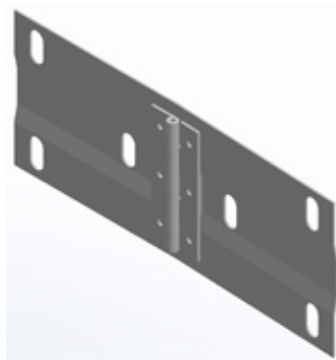

Nối xoay ngang trong  
Connector for inner horizontal hinge

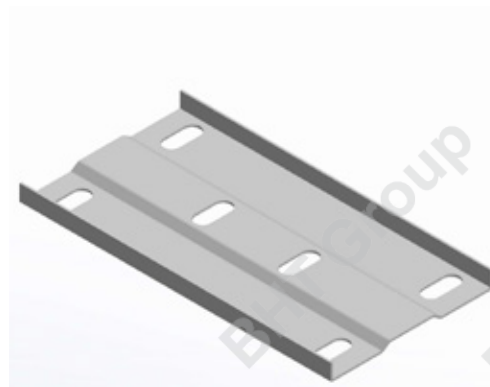

Pass nối chắn cạnh 10  
10cm straight connector

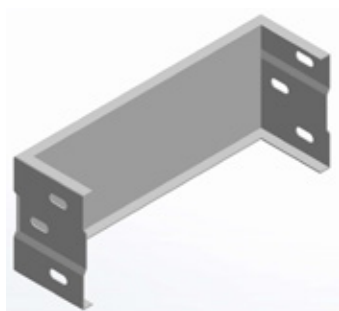

Chặn cuối  
Endcap



Cùm Treo Lổ Chấn U  
Shackles Hanging Barrier U

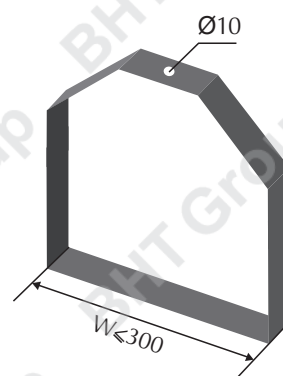

Cùm Treo Máng Cáp  
Clevirs Hange



Giá đỡ chữ A  
Support A

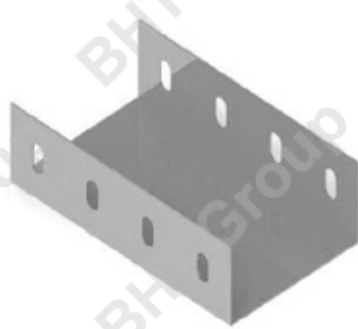

Pass nối chữ U  
Connector U

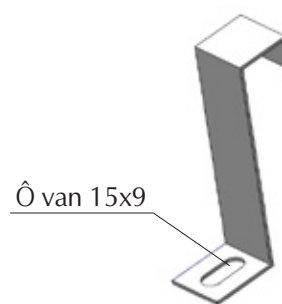

Pass kẹp Z  
Hold down clamp

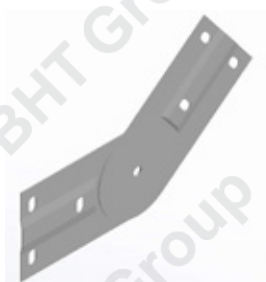

Nối xoay đứng  
Vertical Adjustable connector



Pas kẹp Ω  
Clamp



Thanh ren - Bu lông, đai ốc  
Threaded rod - Bulong



[www.bht.vn](http://www.bht.vn)

#### HEAD OFFICE - HO CHI MINH

1050/14 Pham Van Dong street, quarter 9, Hiep Binh Chanh ward, Thu Duc city, Ho Chi Minh city.  
Phone: 0912 254 419  
Email: [bht@bht.vn](mailto:bht@bht.vn)

#### BHT BINH DUONG FACTORY

Lot B2, 3rd street, Tan Dong Hiep B Industrial Zone, Di An, Binh Duong.  
Phone: (0274) 377 6162 - 377 6163

#### BHT HOA AN FACTORY

102/22A Huynh Man Dat, Binh Hoa quarter, Hoa An ward, Bien Hoa, Dong Nai.  
Phone: (0251) 2860 364

#### BHT DA NANG FACTORY

Hoa Nhon Industrial Park, Hoa Vang district, Da Nang city.  
Phone: (0236) 3727 656 - 3727 657

#### RAMAN TECH CAMBODIA FACTORY

Ltd No.494, National Road 01, Yokbath Vallige, Sang - kat Kbal Koh, Khan Chbar Ompov, Phnom Penh City.

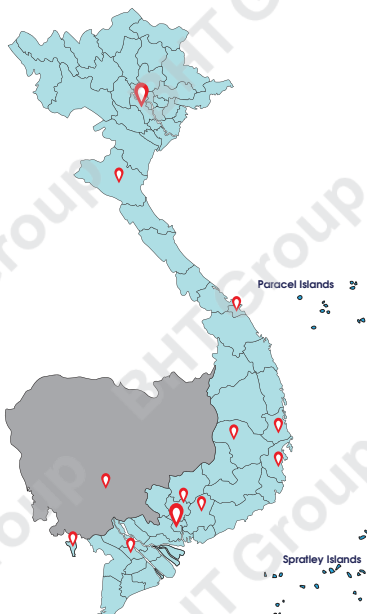

#### CHI NHÁNH *Branches*

**HA NOI:** No. 25, Lane 43/19 Luu Huu Phuoc, Cau Dien ward, Nam Tu Liem district, Hanoi.  
Phone: (024) 3200 1925

**NGHE AN:** An Phat Complex building, No. 20, Avenue 72M, Nghi Phu ward, Vinh city, Nghe An province.  
Phone: 0982 858 290

**DA NANG:** No.234 Nguyen Tri Phuong street, Chinh Gian ward, Thanh Khe district, Da Nang city.  
Phone: (0236) 3727 656 - 3727 677

**PHU YEN:** No.122 Nguyen Hue street, Tuy Hoa, Phu Yen.  
Phone: (0257) 3838 868

**NHA TRANG:** STH23A-24, 1A street, Le Hong Phong urban area 2, Phuoc Hai ward, Nha Trang city, Khanh Hoa.  
Phone: (0258) 3875 265

**BUON MA THUOT:** No.191 Mai Hac De street, Tan Thanh, Buon Me Thuot, Dak Lak.  
Phone: (0262) 3843 517

**PHU QUOC:** Villa Phong Nha 3, Bung Goi hamlet, Cua Duong commune, Phu Quoc, Kien Giang.  
Phone: 0903 809 445

**BINH DUONG:** Lot B2, 3rd street, Tan Dong Hiep B Industrial Zone, Di An, Binh Duong.  
Phone: (0274) 3776 162

**BIEN HOA:** No.102/22A Huynh Man Dat Street, Hoa An ward, Bien Hoa, Dong Nai.  
Phone: (0251) 2860 364