



BHT Group

CATALOGUE

TRỤ ĐÈN

LIGHTING POLES



www.bht.vn

CÔNG TY THÀNH VIÊN
MEMBER CORPORATION



GIỚI THIỆU

INTRODUCTION

BHT Group là đơn vị hàng đầu tại Việt Nam chuyên sản xuất và cung cấp các thiết bị giao thông. Chúng tôi tự hào về đội ngũ kỹ sư trẻ năng động và công nhân lành nghề, cùng với hệ thống quản lý chất lượng theo tiêu chuẩn ISO 9001:2015. Điều này nhằm đảm bảo rằng chúng tôi luôn mang đến cho khách hàng những sản phẩm chất lượng hàng đầu, mẫu mã đẹp mắt và giá thành hợp lý.

BHT Group is a leading unit in Vietnam specializing in manufacturing and supplying traffic equipment. We are proud of our team of young, dynamic engineers and skilled workers, along with a quality management system in accordance with ISO 9001:2015 standards. This ensures that we always provide customers with top-quality products, beautiful designs, and reasonable prices.

Các sản phẩm chủ lực của công ty chúng tôi/ *Our company's key products:*

- Trụ đèn giao thông và trụ đèn chiếu sáng/ *Traffic light poles and lighting poles.*
- Hộ lan mềm 2 sóng, 3 sóng/ *2-wave, 3-wave soft guardrails.*
- Lan can cầu/ *Bridge railing.*
- Nắp mương thoát nước/ *Drainage ditch covers.*
- Gương chống lóa, bulong,... / *Anti-glare mirrors, bolts,...*

Với nhiều năm kinh nghiệm trong lĩnh vực cung cấp các thiết bị giao thông, hệ thống chiếu sáng cho các dự án hạ tầng giao thông, khu công nghiệp, khu dân cư,... Chúng tôi tự hào là đối tác của các đơn vị đầu tư và xây lắp hạ tầng hàng đầu Việt Nam như: tập đoàn Sơn Hải, tập đoàn Đèo Cả, tổng công ty Đầu tư Xây dựng 194, tập đoàn Hải Đăng, tập đoàn Thăng Long và BQL hạ tầng giao thông các tỉnh thành, các nhà đầu tư BOT trên cả nước,...

With many years of experience in providing traffic equipment, lighting systems for infrastructure projects, industrial zones, residential areas, etc., we are proud to be a partner of leading infrastructure investment and construction units in Vietnam such as: Son Hai Group, Deo Ca Group, Construction Investment Corporation 194, Hai Dang Group, Thang Long Group and Infrastructure Management Board of provinces and cities, BOT investors nationwide,...

Với nền tảng công nghệ sản xuất tiên tiến, chúng tôi tự tin rằng sẽ sản xuất & cung cấp các sản phẩm đa dạng, đạt chất lượng cao và toàn diện hơn đến các dự án giao thông trên toàn quốc.







With our advanced manufacturing technology platform, we are confident that we will manufacture & supply more diverse, higher quality, and comprehensive products to transportation projects nationwide.



Các sản phẩm cột thép chiếu sáng của công ty chúng tôi được sản xuất trên một hệ thống dây chuyền công nghệ hiện đại và đồng bộ, với năng lực công nghệ tiêu biểu: Nhà xưởng công nghiệp; 01 dây chuyền cán lá phẳng và cắt tôn thép bán tự động NC; 2 máy chấn tôn thủy lực CNC 12m x 1.600 tấn; 04 máy hồ quang chìm (SAW); 01 máy nắn thẳng ba hướng ép và các thiết bị chuyên dụng khác...

Our company's steel lighting pole products are manufactured on a modern and synchronized technological production line, with typical technological Industrial workshop; 01 semi-automatic NC flat rolling and steel plate cutting line; 2 CNC hydraulic press brakes 12m x 1,600 tons; 04 submerged arc welding (SAW) machines; 01 three-direction straightening press and other specialized equipment.

Quy trình sản xuất trụ đèn Manufacturing process

<p>1</p>  <p>Chuẩn bị nguyên liệu: Thép tấm <i>Prepare material: Steel</i></p>	<p>2</p>  <p>Đột - cắt tự động CNC <i>CNC - U automatic punching & cutting process</i></p>	<p>3</p>  <p>Quy trình hàn <i>Welding process</i></p>
<p>4</p>  <p>Vệ sinh công nghiệp <i>Industrial hygiene</i></p>	<p>5</p>  <p>Mạ kẽm nhúng nóng <i>Hot dip galvanizing process</i></p>	<p>6</p>  <p>Quy trình kiểm tra, đóng gói, xuất xưởng <i>Checking, packing and shipping</i></p>

Chứng nhận, chứng chỉ / *Certificates:*

1. ISO 9001 - 2015
2. QCVN 16:2014/BXD
3. ASTM A123M-17



I. TỔNG QUAN TRỤ ĐÈN / LAMP POLES OVERVIEW

1. Trụ đèn liền cần/ Lamp poles with curved bracket

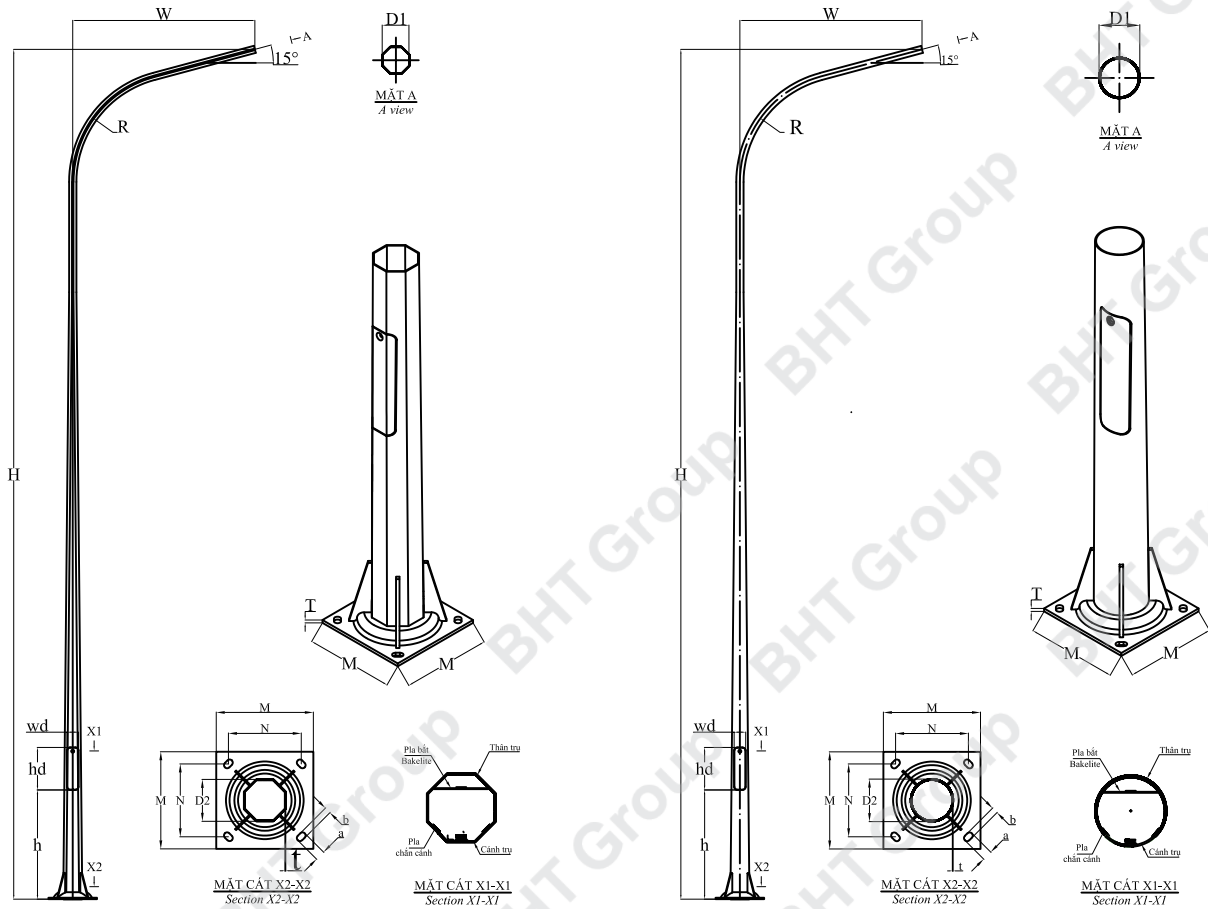

Trụ thép bát giác côn liền cần

Octagonal tapered lamp poles integral with curved bracket

Trụ thép tròn côn liền cần

Circular tapered lamp poles integral with curved bracket

KÝ HIỆU / ABBREVIATIONS:

H: Chiều cao trụ
Height of pole

W: Chiều dài vươn cần
Length of outreach bracket

R: Bán kính uốn cần
Bending radius

wd: Chiều rộng cánh trụ
Wing-pole width

D1: Đường kính ngọn
Top diameter

D2: Đường kính gốc
Bottom diameter

M: Kích thước đế trụ
Dimension of base pole

hd: chiều cao cánh trụ
Wing-pole height

N: Kích thước tim lỗ móng trụ
Dimensions of the center of footing base

T: Độ dày đế trụ
Thickness of base pole

h: Khoảng cách từ mặt dưới đế
trụ đến mặt dưới cánh trụ
Distance from bottom base pole to
under wing-pole

a: Chiều rộng lỗ bắt bulong móng
Width of anchor bolts

b: Chiều dài lỗ bắt bulong móng
Length of anchor bolts

t: Độ dày thân trụ
Thickness of pole

THÔNG SỐ KỸ THUẬT CỘT THÉP TRÒN CÔN LIỀN CẦN / Technical Specifications

Tên gọi Reference	Độ cao Height(H)	Độ dày Thickness (T)	Đường kính đáy Bottom (D2)	Đường kính ngọn Top (D1)	Đế trụ Base pole (M)	Tâm bulong Center bolts (N)
	m	mm	mm	mm	mm	mm
BHT – TC 6m	6	3 - 3.5	133 - 150	60 - 76 - 84	375 x 375 x10	300 x 300
BHT – TC 7m	7	3 - 3.5	150 - 156	60 - 76 - 84	375 x 375 x10	300 x 300
BHT – TC 8m	8	3 - 3.5 - 4	150 - 190	60 - 76 - 84	375 x 375 x10	300 x 300
BHT – TC 9m	9	3 - 3.5 - 4	165 - 190	60 - 76 - 84	375 x 375 x10	300 x 300
BHT – TC 10m	10	3.5 - 4	190	60 - 76 - 84	375 x 375 x12	300 x 300
BHT – TC 11m	11	4 - 5	210	60 - 76 - 84	400 x 400 x12	300 x 300
BHT – TC 12m	12	4 - 5	210	60 - 76 - 84	400 x 400 x12	300 x 300

2. Trụ đèn cần rời / Lamp poles without bracket

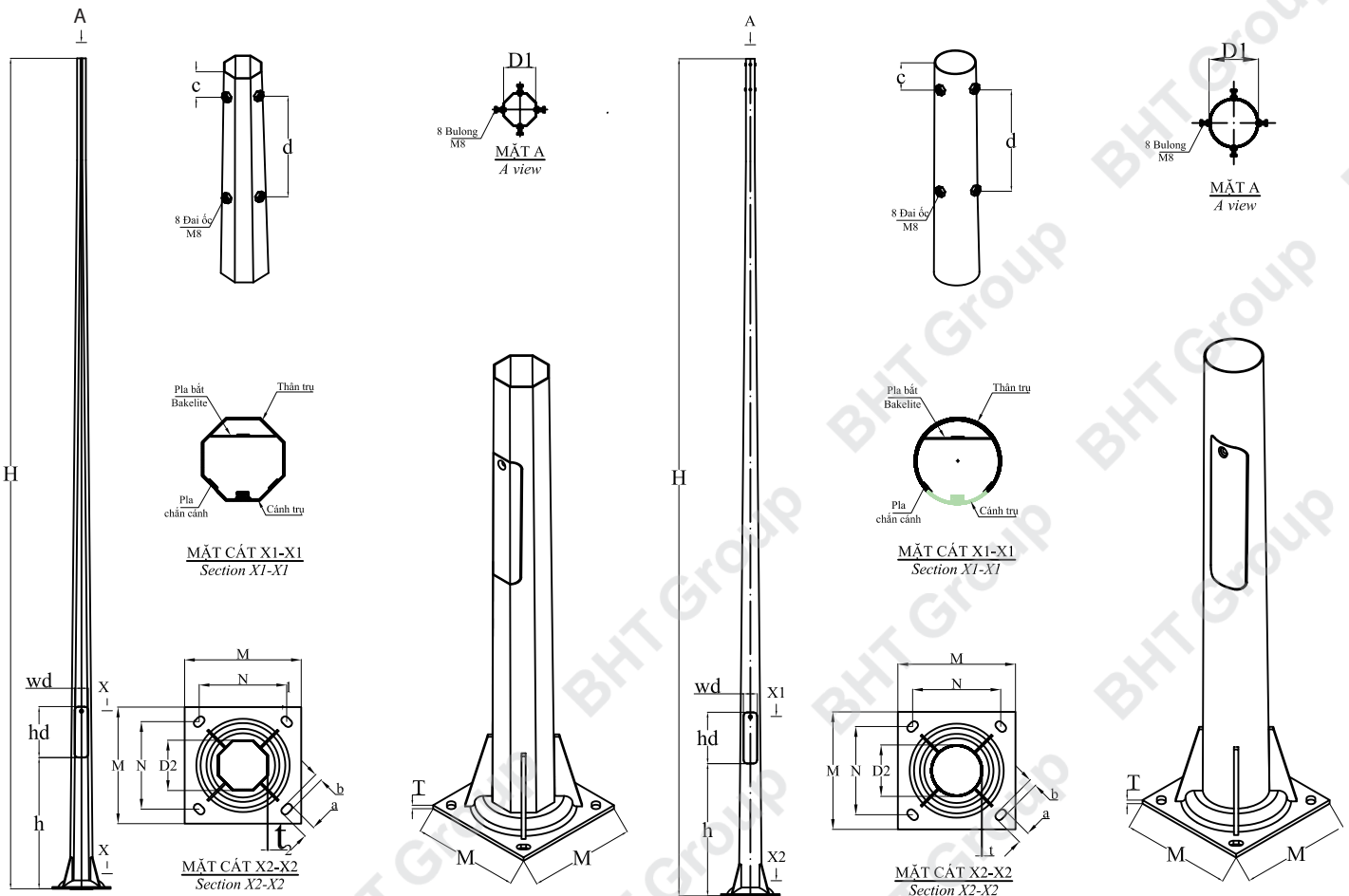

Trụ thép bát giác côn / Octagonal tapered steel poles

Trụ thép tròn côn / Circular tapered steel poles

KÝ HIỆU / ABBREVIATIONS:

H: Chiều cao trụ
Height of pole
W: Chiều dài vươn cần
Length of outreach bracket
R: Bán kính uốn cần
Bending radius
wd: Chiều rộng cánh trụ
Wing-pole width

D1: Đường kính ngọn
Top diameter
D2: Đường kính gốc
Bottom diameter
M: Kích thước đế trụ
Dimension of base pole
hd: chiều cao cánh trụ
Wing-pole height

N: Kích thước tim lỗ móng trụ
Dimensions of the center of footing base
T: Độ dày đế trụ
Thickness of base pole
h: Khoảng cách từ mặt dưới đế trụ đến mặt dưới cánh trụ
Distance from bottom base pole to under wing-pole

a: Chiều rộng lỗ bắt bulong móng
Width of anchor bolts
b: Chiều dài lỗ bắt bulong móng
Length of anchor bolts
c: Khoảng cách từ ngọn trụ đến tâm đai ốc M8
Distance from top base pole to nut center M8
d: Khoảng cách tâm đai ốc
Nut center distance

THÔNG SỐ KỸ THUẬT CỘT THÉP TRÒN CÔN CẦN RỜI / Technical Specifications

Tên gọi Reference	Độ cao Height (H)	Độ dày Thickness (T)	Đường kính đáy Bottom (D2)	Đường kính ngọn Top (D1)	Đế trụ Base pole (M)	Tâm bulong Center bolts (N)
	m	mm	mm	mm	mm	mm
BHT - TCLC 6m	6	3 - 3.5	133 - 150	60 - 76 - 84	375 x 375 x10	300 x 300
BHT - TCLC 7m	7	3 - 3.5	150 - 156	60 - 76 - 84	375 x 375 x10	300 x 300
BHT - TCCL 8m	8	3 - 3.5 - 4	150 - 190	60 - 76 - 84	375 x 375 x10	300 x 300
BHT - TCCL 9m	9	3 - 3.5 - 4	165 - 190	60 - 76 - 84	375 x 375 x10	300 x 300
BHT - TCCL 10m	10	3.5 - 4	190	60 - 76 - 84	375 x 375 x12	300 x 300
BHT - TCCL 11m	11	4 - 5	210	60 - 76 - 84	400 x 400 x12	300 x 300
BHT - TCLC 12m	12	4 - 5	210	60 - 76 - 84	400 x 400 x12	300 x 300

II. CẦN ĐÈN/ ROAD LIGHT BRACKETS

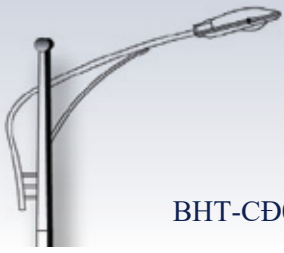

BHT-CD01



BHT-CD02



BHT-CD03

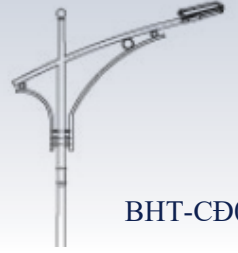

BHT-CD04

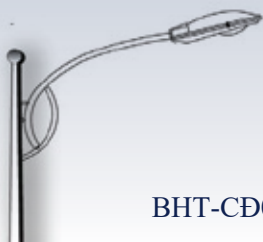

BHT-CD05



BHT-CD06



BHT-CD07



BHT-CD08

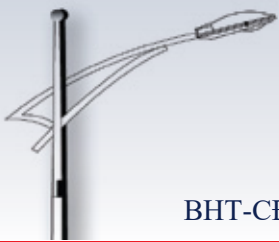

BHT-CD09



BHT-CD10



BHT-CD11



BHT-CD12

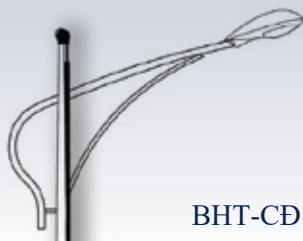

BHT-CD13



BHT-CD14



BHT-CD15

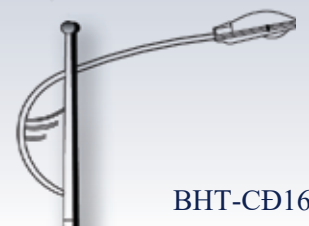

BHT-CD16



BHT-CD17



BHT-CD18



BHT-CD19



BHT-CD20

CÁC MẪU CẦN ĐÈN ĐƠN

Types of single light brackets

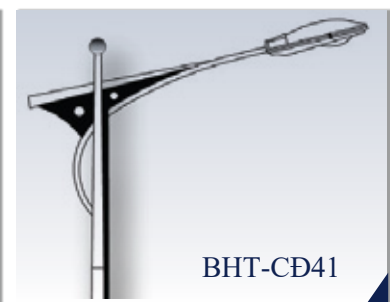
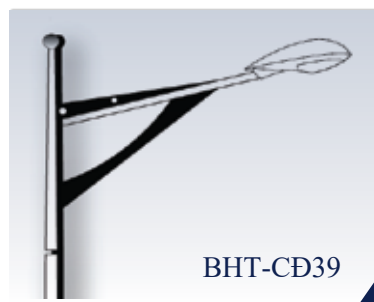
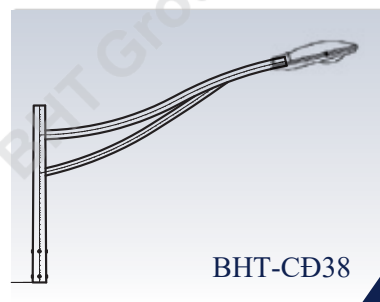
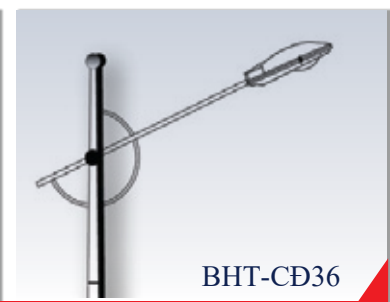
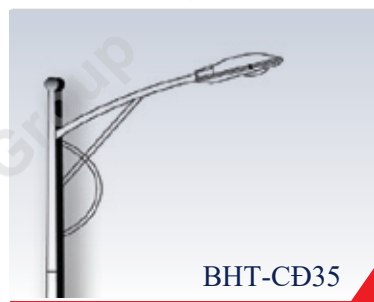
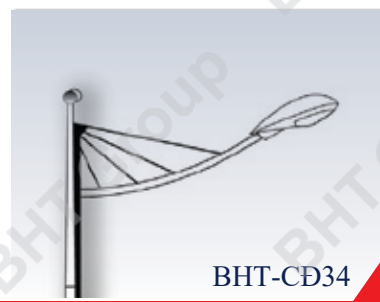
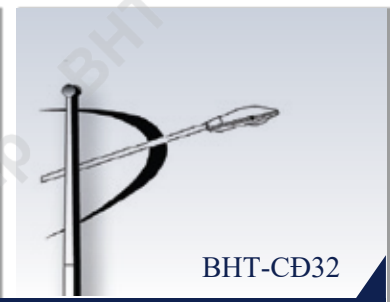
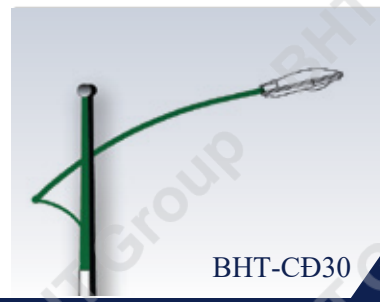
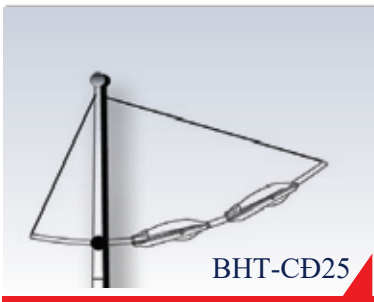

II. CẦN ĐÈN/ ROAD LIGHT BRACKETS

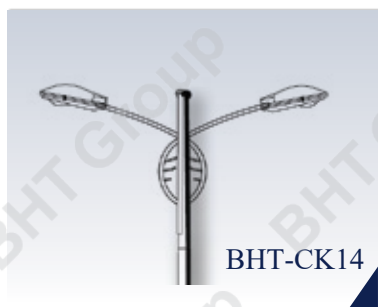
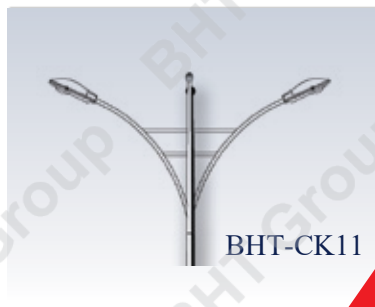
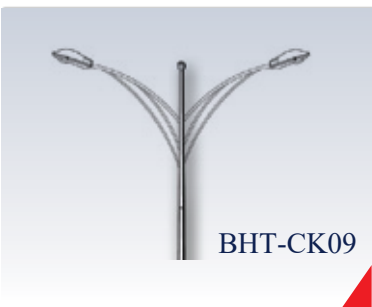
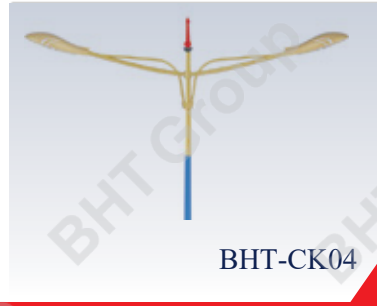

CÁC MẪU CẦN ĐÈN ĐÔI

Types of double light brackets



BHT-CK21



BHT-CK22



BHT-CK23



BHT-CK24



BHT-CK25

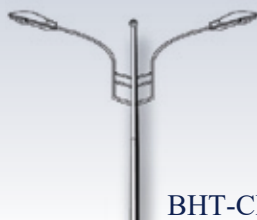

BHT-CK26



BHT-CK27



BHT-CK28



BHT-CK29



BHT-CK30



BHT-CK31



BHT-CK32



BHT-CK33



BHT-CK34



BHT-CK35



BHT-CK36



BHT-CK37

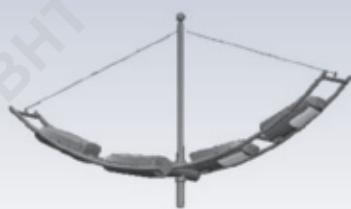

BHT-CK38



BHT-CK39



BHT-CK40

III. TRỤ ĐÈN GIAO THÔNG/ TRAFFIC LIGHT POLE

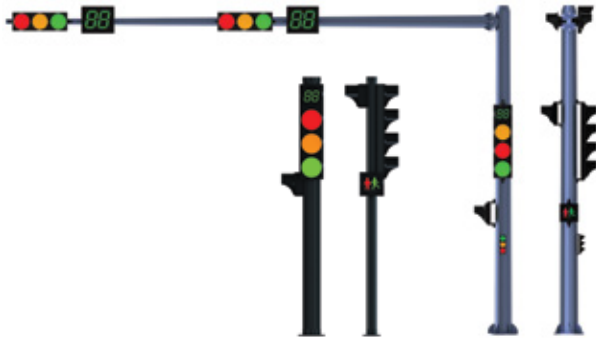

Thông số kỹ thuật/Specifications

THGT	THGT	THGT	THGT
H 2,6 - 3,9m	H 6,2m	H 6,2m	H 6,2m
	L 3-4m	L 5-7m	L 8-10m

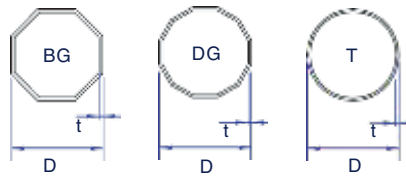

Mặt cắt thân cột
Cross section of pole

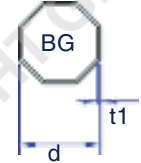

Mặt cắt tay vươn
Cross section of bracket

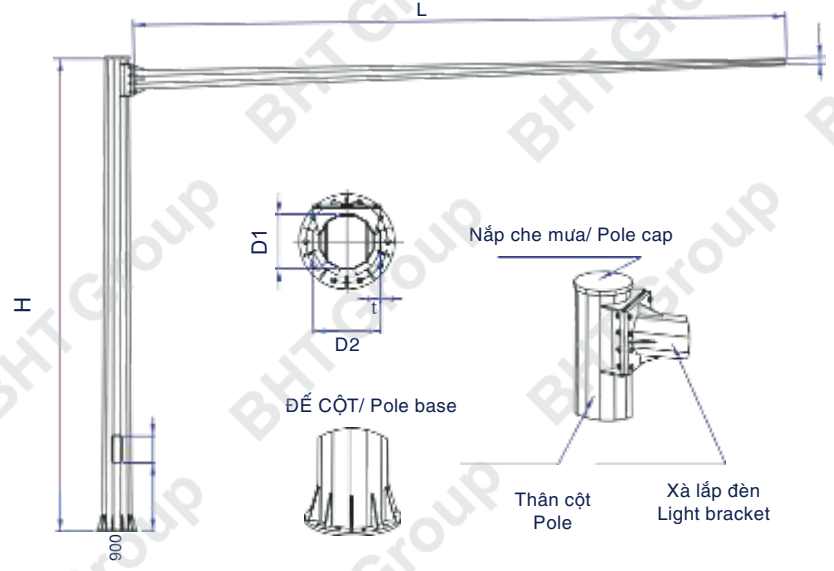
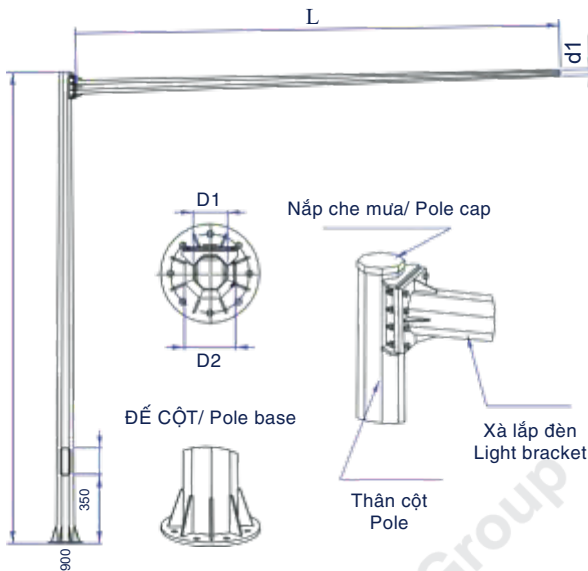

THÔNG SỐ KỸ THUẬT CỘT ĐÈN TÍN HIỆU GIAO THÔNG/ Technical Specifications

Ký hiệu/ Symbols		Thân cột / Pole				Xà lắp đèn / Light bracket			
Thân đa giác Octagonal pole	Thân tròn côn Round pole	H (m)	D1 (m)	D2 (m)	t (m)	L (m)	d1 (m)	d2 (m)	t2 (m)
BHT - ĐG 2,6m	BHT - TC 2,6m	2,6	84/87	110/114	3,0	-	-	-	-
BHT - ĐG 2,9m	BHT - TC 2,9m	2,9	84/87	113/117	3,0	-	-	-	-
BHT - ĐG 3,4m	BHT - TC 3,4m	3,4	84/87	118/123	3,0	-	-	-	-
BHT - ĐG 3,9m	BHT - TC 3,9m	3,4	84/87	123/128	3,0	-	-	-	-
BHT - ĐG 6,2 - D130 W3m	BHT - TC 6,2 - D136 W3m	6,2	130/136	204/210	4,0	3,0	80/90	116/122	4,0
BHT - ĐG 6,2 - D130 W4m	BHT - TC 6,2 - D136 W4m	6,2	130/136	204/210	4,0	4,0	80/90	128/132	4,0
BHT - ĐG 6,2 - D168 W5m	BHT - TC 6,2 - D182 W5m	6,2	168/182	254/256	5,0	5,0	80/90	150/143	5,0
BHT - ĐG 6,2 - D168 W6m	BHT - T C 6,2 - D182 W6m	6,2	168/182	254/256	5,0	6,0	80/90	164/153	5,0
BHT - ĐG 6,2 - D173 W7m	BHT - TC 6,2 - D187 W7m	6,2	173/187	259/261	6,0	7,0	80/90	178/164	5,0
BHT - ĐG 6,2 - D220 W8m		6,2	220	307	6,0	8,0	80	208	5,0
BHT - ĐG 6,2 - D320 W9m		6,2	320	400	6,0	9,0	80	242	6,0
BHT - ĐG 6,2 - D320 W10m		6,2	320	400	6,0	10,0	80	260	6,0

GIÁ LONG MÔN

Traffic guide posts



KHUNG LƯỚI CHỐNG LÓA

Anti-glare mesh



LAN CÀN CẦU

Bridge railing



BULONG

Bulong



NẮP CỔNG

Manhole cover

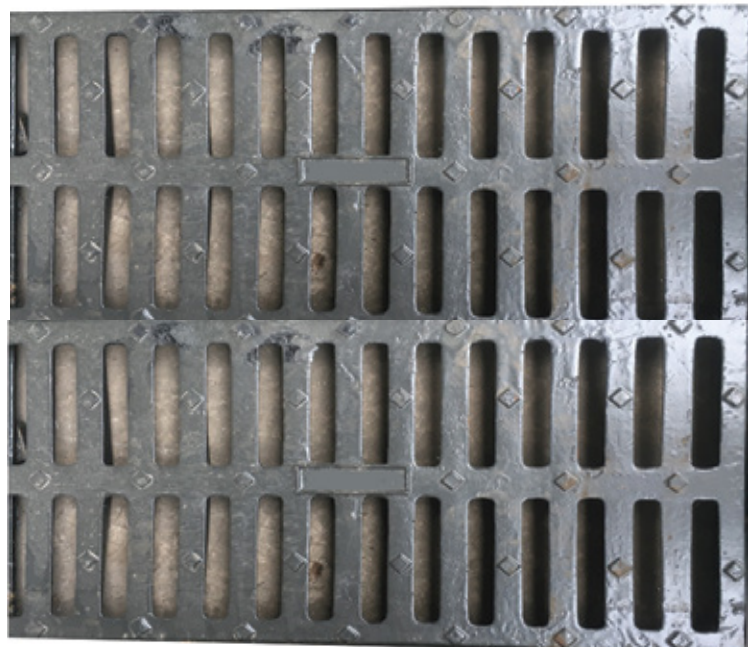

IV. HỘ LAN MỀM / SOFT BALUSTRADE WALL



HỘ LAN 2 SÓNG / Guard rail 2 waves



HỘ LAN 3 SÓNG / Guard rail 3 waves

MÁY SẢN XUẤT HỘ LAN
Machine soft balustrade wall

Quy trình sản xuất hộ lan

Manufacturing process



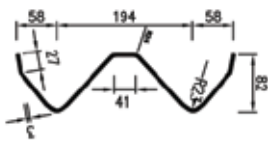

Mặt cắt A-A
Cross section A-A

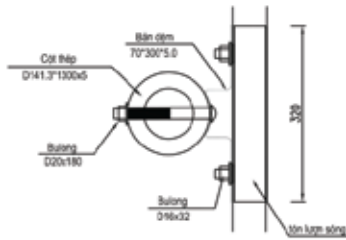

Mặt cắt B-B
Cross section B-B

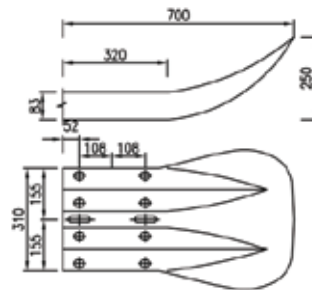

Chi tiết đầu thanh
Tôn lượn sóng

THÔNG SỐ KÍCH THƯỚC / Technical Specifications

Bước cột Wavelength	2 sóng/ 2 waves		3 sóng/ 3 waves	
	Chiều dài (L)	Chiều cao (H)	Chiều dài (L)	Chiều cao (H)
2m	2,32	0,31	2,32	0,45
3m	3,32	0,31	3,32	0,45
4m	4,32	0,31	4,32	0,45
6m	6,32	0,31	6,32	0,45
7m	7,32	0,31	7,32	0,45

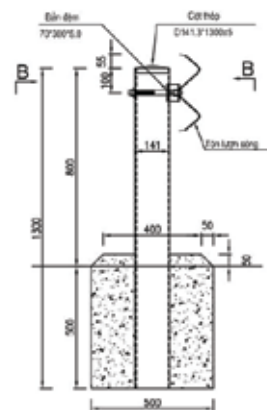
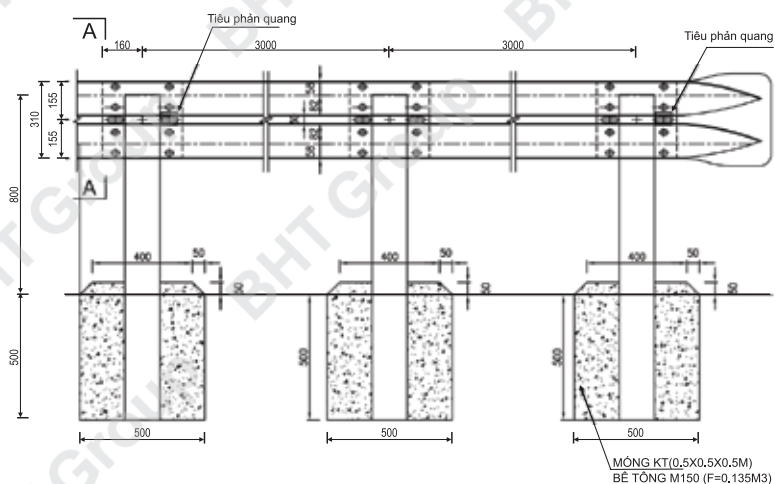

V. ĐỐI TÁC TIÊU BIỂU / STRATEGIC PARTERSHIP

CHỦ ĐẦU TƯ / INVESTOR



BECOMEX



TCIP



NHÀ CUNG CẤP / SUPPLIER



POSCO



Thép VINAONE



ĐỐI TÁC TÀI CHÍNH / FINANCIAL PARTNER



AGRIBANK



CÔNG TRÌNH TIÊU BIỂU / *TYPICAL PROJECTS*



KĐT Cityland Park Hills (TP.HCM)



KĐT Swan Bay Đại Phước (TP.HCM)



Cao tốc Cam Lâm - Vĩnh Hào



Condotel Phú Quốc (Phú Quốc)



KCN Vsip Quảng Ngãi (Quảng Ngãi)



Đại lộ Đông Tây (TP. HCM)



Central Island - Cù Lao Tân Vạn



Đường vành đai Bình Lợi - Tân Sơn Nhất



KTX ĐH Quốc Gia TP. HCM



KDC Đông Sài Gòn (TP. HCM)



Tuyến đường Metro (TP. HCM)



NM nhôm Toàn Cầu (Bà Rịa - Vũng Tàu)



KCN Hồ Nai (Đồng Nai)



HEAD OFFICE - HO CHI MINH

1050/14 Pham Van Dong street, quarter 9, Hiep Binh Chanh ward, Thu Duc city, Ho Chi Minh city.
Phone: 0912 254 419
Email: bht@bht.vn

BHT BINH DUONG FACTORY

Lot B2, 3rd street, Tan Dong Hiep B Industrial Zone, Di An, Binh Duong.
Phone: (0274) 377 6162 - 377 6163

BHT HOA AN FACTORY

102/22A Huynh Man Dat, Binh Hoa quarter, Hoa An ward, Bien Hoa, Dong Nai.
Phone: (0251) 2860 364

BHT DA NANG FACTORY

Hoa Nhon Industrial Park, Hoa Vang district, Da Nang city.
Phone: (0236) 3727 656 - 3727 657

RAMAN TECH CAMBODIA FACTORY

Ltd No.494, National Road 01, Yokbath Vallige, Sang - kat Kbal Koh, Khan Chbar Ompov, Phnom Penh City.

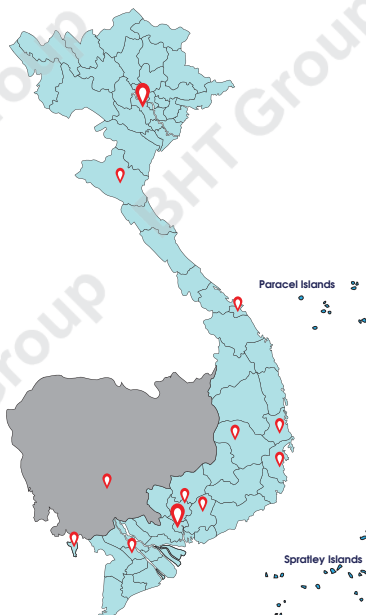

CHI NHÁNH

Branches

HA NOI: No. 25, Lane 43/19 Luu Huu Phuoc, Cau Dien ward, Nam Tu Liem district, Hanoi.
Phone: (024) 3200 1925

NGHE AN: An Phat Complex building, No. 20, Avenue 72M, Nghi Phu ward, Vinh city, Nghe An province.
Phone: 0982 858 290

DA NANG: No.234 Nguyen Tri Phuong street, Chinh Gian ward, Thanh Khe district, Da Nang city.
Phone: (0236) 3727 656 - 3727 677

PHU YEN: No.122 Nguyen Hue street, Tuy Hoa, Phu Yen.
Phone: (0257) 3838 868

NHA TRANG: STH23A-24, 1A street, Le Hong Phong urban area 2, Phuoc Hai ward, Nha Trang city, Khanh Hoa.
Phone: (0258) 3875 265

BUON MA THUOT: No.191 Mai Hac De street, Tan Thanh, Buon Me Thuot, Dak Lak.
Phone: (0262) 3843 517

PHU QUOC: Villa Phong Nha 3, Bung Goi hamlet, Cua Duong commune, Phu Quoc, Kien Giang.
Phone: 0903 809 445

BINH DUONG: Lot B2, 3rd street, Tan Dong Hiep B Industrial Zone, Di An, Binh Duong.
Phone: (0274) 3776 162

BIEN HOA: No.102/22A Huynh Man Dat Street, Hoa An ward, Bien Hoa, Dong Nai.
Phone: (0251) 2860 364